

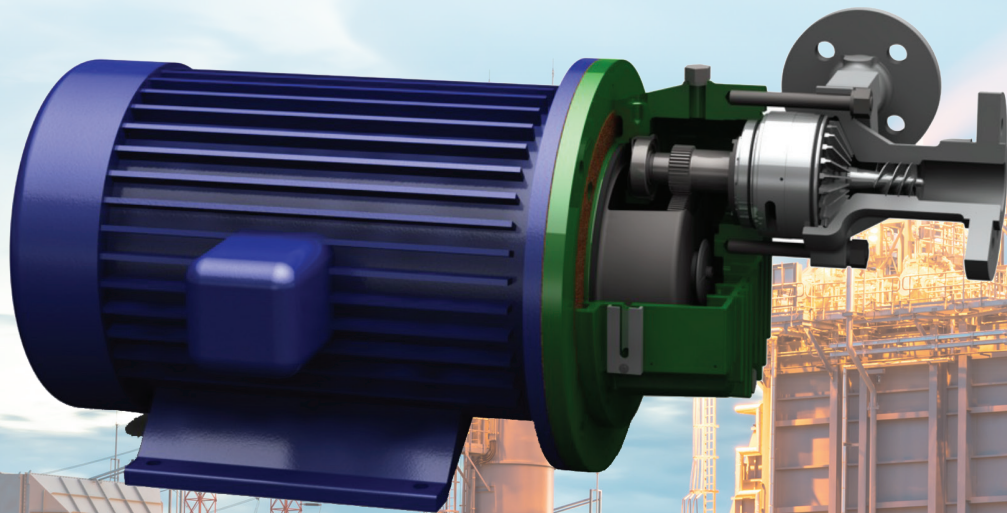

Sunflo Reliable Boiler Feed Pumps

The Most Versatile Industrial Grade Pump for High Pressure Water Applications

Sunflo Pumps have a Long and Successful Track Record Handling Boiler Feed Water, Condensate and De-superheating applications in Power Stations and Industrial Facilities Ranging up to 25MW



Sunflo pumps are specifically designed for High Pressure applications such as boiler feed, NOx suppression, reverse osmosis, or high pressure wash down applications that are common to power generation, maritime, transportation or food & beverage industries.

Common Applications for Sunflo Pumps:

- Boiler Feed
- NOx Suppression
- Dust Suppression
- Equipment Washdown
- Surface Cleaning
- Tank Cleaning
- Food & Beverage

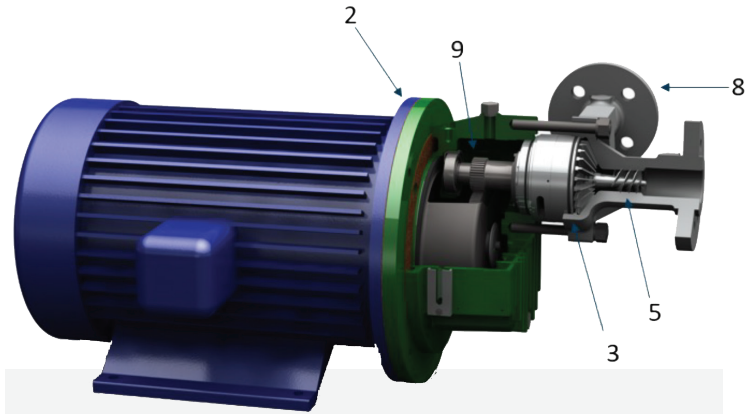

Operating Reliability

1. Built in Thrust Runner to withstand suction transient conditions
2. Close Coupled design to eliminate alignment concerns
3. Multiple flush plans offered based on the process temperature

Performance Data:

- Capacity: Up to 550 gpm
- Head: Up to 5,500 ft
- Temperature: up to 350°F
- Speed: Up to 21,000 rpm
- Frequency: 50/60Hz
- Inverter Ready

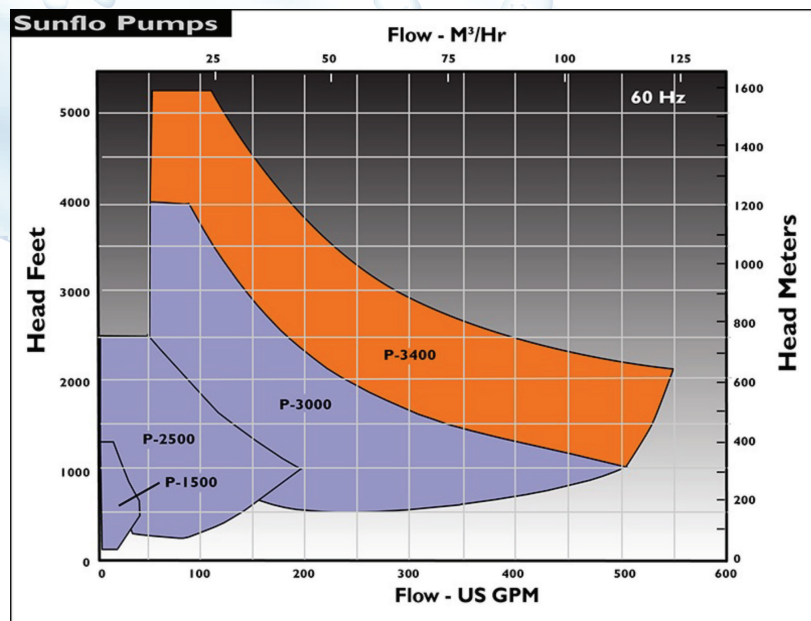

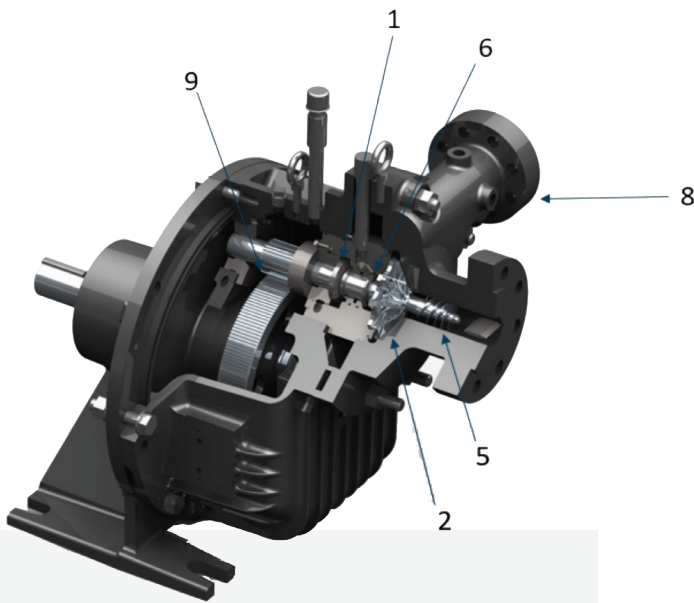

Service Life

4. 316 Stainless Steel Construction
5. Low NPSHr due Sundyne Inducer Technology to provide a custom sized inducer based on the demand of the application
6. Process Seal components designed for Ultra-pure water

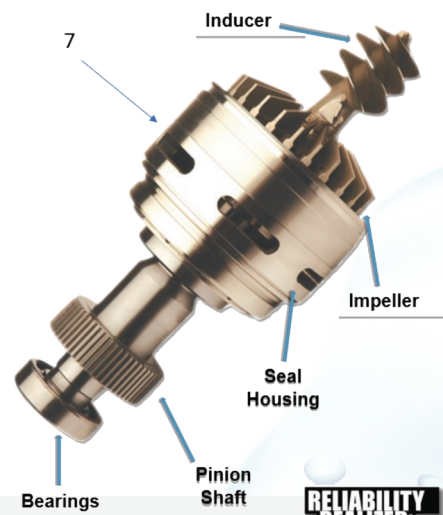

**RELIABILITY
REALIZED.**

Sustainability

7. Removable Shaft Assembly to allow for minimum down time
8. Discharge Orientation can be rotated every 90 degrees for ease of install
9. Multi-stage performance in a single stage pump

Materials of Configuration

- Process Side: 316SS
- Gearbox: Aluminum
- Gears and Shaft: Steel per Agma Rating
- Seal Plans: Plan 11, 13, 21, 23, or 53/54
- Seal Material: Carbon, Silicon Carbide, Metalized Carbon

Single stage Sunflo pumps leverage the engineering expertise and the legacy of Sundyne heavy duty API integrally geared pumps to create industrial grade pumps that save energy and water through efficient high-pressure pumping.

Backed By Global Support

Sundyne is more than just a manufacturer of high quality compressors and pumps. We offer some of the fastest delivery times in the industry, and we back each product shipped with a full range of aftermarket support services, extending the value of our highly engineered machines well beyond the point of sale.

And with our engineered solutions, worldwide presence and compact designs, installation and maintenance has never been more efficient.

The Sundyne service team is here to help protect your investment and provide a trouble-free customer experience at every turn. That's **RELIABILITY REALIZED.**

Our Aftermarket Programs Include:

- Gearbox Exchanges & Upgrades
- Maintenance Kits
- Conversion Programs
- On-Site SundSCHOOL
- Field Service Support
- Overhaul and Repair Services
- Site Surveys
- Emergency Expedite Services

Sundyne: An OSHA VPP Star Site

At Sundyne, Environmental Health and Safety (EH&S) is integral to our culture of excellence, and providing a 100% safe work environment through the manufacturing and installation phases of a project is a core priority.

To learn more about our extended service offerings and specific application references, visit www.sundyne.com or contact us toll free at 1-866-SUNDYNE.



For more information please
visit www.sundyne.com
and fill out the
Contact Me form.
A Sundyne representative
will contact you.



Sundyne Headquarters:

Sundyne, LLC
14845 West 64th Avenue
Arvada, Colorado 80007 USA
Toll Free: 1-866-Sundyne
Phone: +1-303-425-0800

Sundyne France:

Sundyne International S.A.
13-15, Bld. Eiffel - B.P. 30
21604 Longvic Cedex France
Phone: +33 (0)3 80 38 33 00
Fax: +33 (0)3 80 38 33 66

Sundyne Asia Japan Co., Ltd.

Odakyu Dai-Ichi Seimei Bldg, 6F
2-7-1, Nishi-Shinjuku Shinjuku-Ku
Tokyo, 163-0706 Japan
Phone: +81-3-3344-0911

Sundyne India

4 + 5, L-Square
Near Parihar Chowk
Pune, 411 007 India
Phone: +91 99870 76165