

Technical Profile

GSPV

Vertical inline sealless magnetic drive pumps to API 685 (2nd edition)

The GSPV range of vertical pumps caters for a variety of applications such as booster packages, condensate transfer, hydrocarbon transfer and sampling packages. Its compact design particularly lends itself to offshore applications where space is a premium.

The use of fixed diffuser parts outboard of the impeller instead of volutes optimises the best efficiency point and head rise to shut-off for a range of impeller flow trims. The high flow diffuser options offer higher efficiency values than single volute designs.

A major advantage of having a diffuser is a significant reduction in radial loads and the consequential low vibration levels experienced and stabilisation of the characteristic head curve.

The rigidly coupled vertically-mounted design has nine hydraulics split between two frame sizes to suit the power requirements, with the option of ZeroLoss™ shells in all configurations.

Performance of the GSPV Range

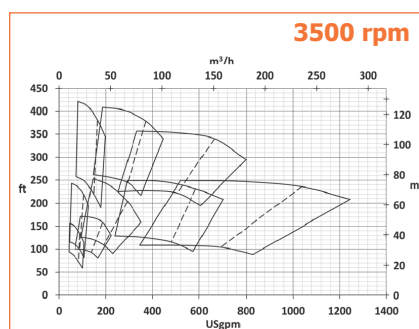
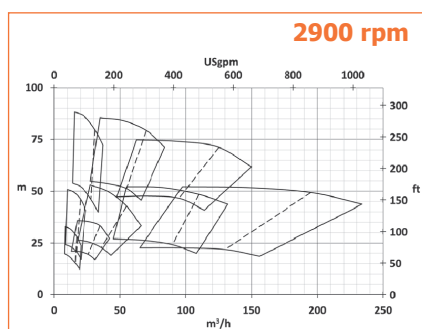
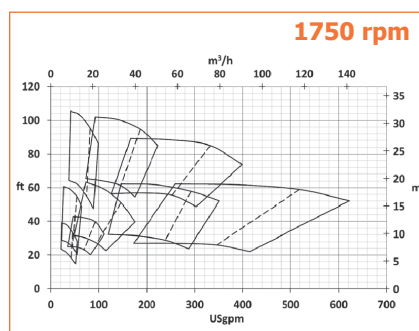
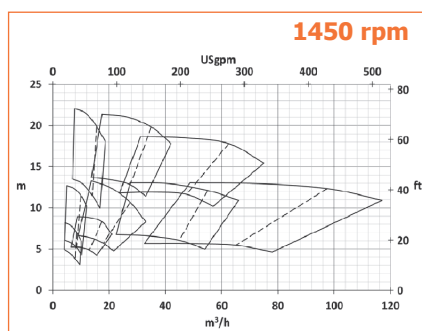

HMD Kontro



Design range limits

The GSPV pump is designed to operate from -40°C to 205°C for the standard material Class A-8. With specific material selection the minimum temperature limits can be extended to -100°C. The maximum process temperature limit is governed by the rigidly coupled vertical motor configuration.

Design working pressure is 40 bar/580 psi. Design pressures up to 100 bar (1400 psi) available on request.

Solids handling

The unit is capable of handling solids up to 5% w/w with 100 microns.

Materials of construction

Pump material available as standard in stainless steel (A-8), carbon steel (S-5) and duplex (D-1 and D-2). Other variations available on request.

Options

- High efficiency ZL containment shell
- Secondary control system
- Secondary containment system
- External filtration
- NACE compliant materials
- High system pressure derivatives (100 bar)
- Casing drains flanged or screwed
- Flanged coupling housing drain and vent

Pump models

No.	Hydraulic	Frame	ZL Option
1	20E – 2 x 2 x 6	1	Y
2	20F – 2 x 2 x 8	1	Y
3	30E – 3 x 3 x 6H	1	Y
4	40F – 4 x 4 x 8H	1	Y
5	30G – 3 x 3 x 10	2	Y
6	40G – 4 x 4 x 10	2	Y
7	50F – 6 x 6 x 8H	2	Y
8	50G – 6 x 6 x 10H	2	Y
9	60F – 8 x 8 x 8H	2	Y

Key design features

- Vertically mounted design available in nine hydraulic sizes
- Two basic frame sizes to suit power requirements
- System pressures up to 40 bar (higher pressures available upon request)
- Vertical inline rigidly coupled design (OH4)
- Compliant to BS4082 dimensions
- High efficiency magnet drive
- Silicon carbide internal bearings
- No seals
- Various flange options are available as standard
- ASME VIII containment shell
- Full range of secondary control / containment systems available on request
- Wide range of instrumentation systems available
- Option of high efficiency ZeroLoss™ composite shell
- Material options available

Benefits of the GSPV pump range

The vertically mounted GSPV pump provides all of the benefits of a magnetic drive sealless pump in a compact package. Requiring minimum floor space, the GSPV meets all of the requirements of API 685, making it ideal for chemical and petrochemical, oil and gas applications, including those where space is at a premium, such as in offshore installations. Dimensionally the range conforms to BS4082, thus providing a sealless upgrade solution to existing installations.

With nine hydraulics, and a standard design pressure of 580 psi / 40 bar, the GSPV is suitable for many applications and offers significant advantages and benefits over conventional sealed designs:

- No costly seal support systems to specify, install or maintain
- Reduced specification time and installation costs
- Almost zero unplanned maintenance
- Absolutely no leakages
- Environmentally safe
- Fully encapsulated magnets
- Standard electric motors utilised
- No cooling required up to 205°C
- Non sparking bump ring for safety
- Sundyne HMD Kontro worldwide service support
- Complete fluid containment
- Zero emissions
- Zero contamination of pumped liquid
- Cost effective installation
- Longer MTBF
- No EPA monitoring required
- Improved operator safety and protection of the environment
- Small foot print

Construction of GSPV pump

Illustration shows a Frame 1 pump (20E 2x2x6)

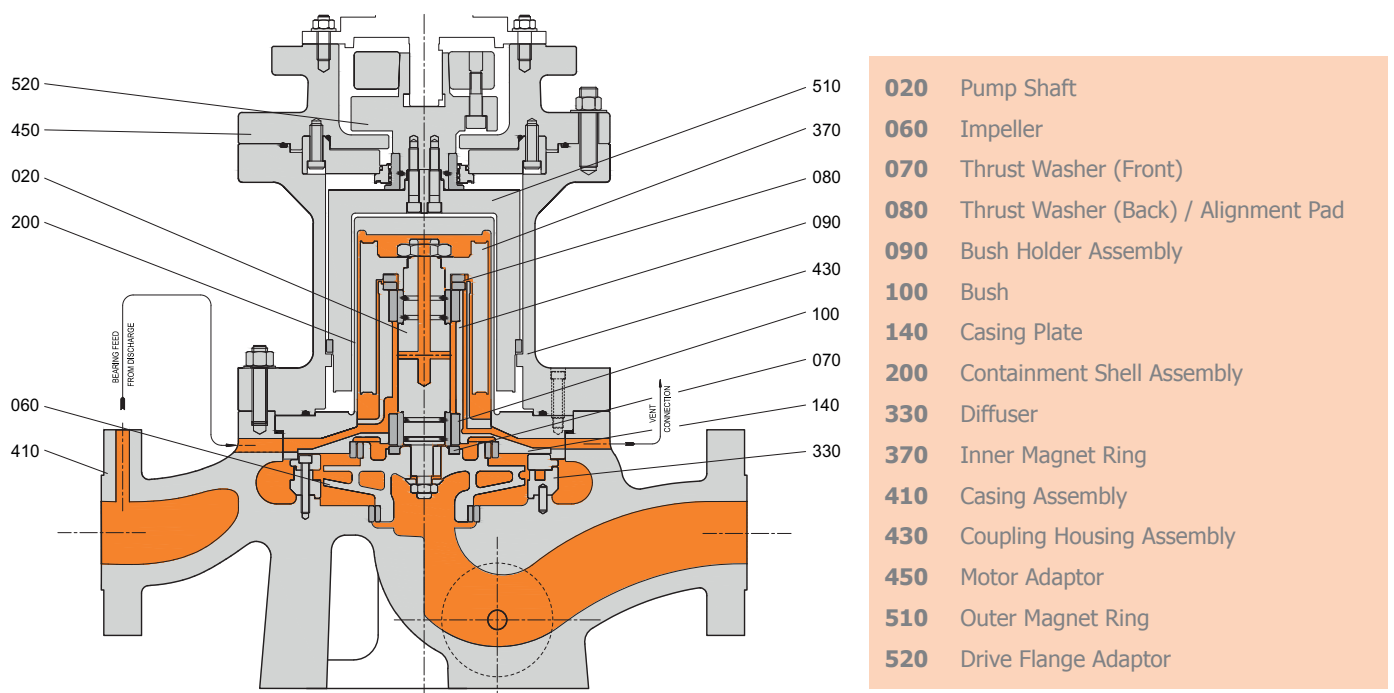

Flanges and connections

Casing

Suction and discharge flanges are designed in accordance with the following relevant standards:

ANSI B16.5 Class 300 Machined with 2mm (1/16") high raised face having a continuous spiral groove.

DIN 2545 PN40 Machined with 2mm high raised face with a continuous spiral groove (Note: these flanges are identical to BS 4504 PN40).

Range capabilities

Frequency Head Flow Temperature Pressure

50 Hz	90m	235 m ³ /h	-40°C to +205°C	40 bar
60 Hz	430ft	1250 USgpm	-40°F to +400°F	580 psi

Note 1: Pressures up to 100 bar (1450 psi) available on request
Note 2: Optional instrumentation packages available

Flange Loadings

Allowable flange loadings imposed by pipework are in accordance with Table 4 of API 685 2nd edition.

Drain Connections

The following drain options are available:

Standard: Frame 1 - 1/2" Pipe with Weld Neck Flange, gusseted in two planes
Frame 2 - 3/4" Pipe with Weld Neck Flange, gusseted in two planes.

Optional: No Drain.

Vent Connections

The following vent options are available:

Standard: Frame 1: 1/2" Pipe with Weld Neck Flange, gusseted in two planes
Frame 2: 3/4" Pipe with Weld Neck Flange, gusseted in two planes.

Gauge Connections

Suction and discharge flanges are fitted with bosses suitable for drilling.

Dimensions of a typical GSPV pump

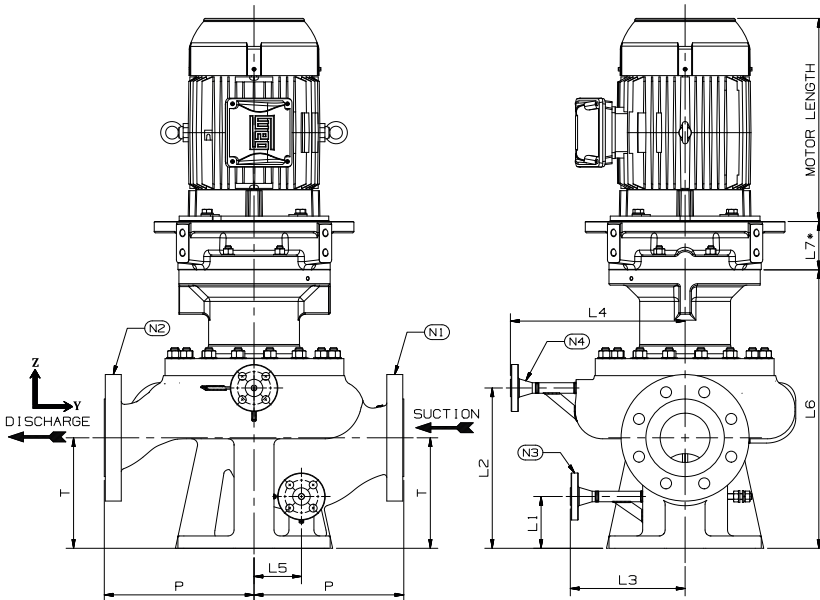

* For full dimensional details see HMD Drawing X9750 which is available on request

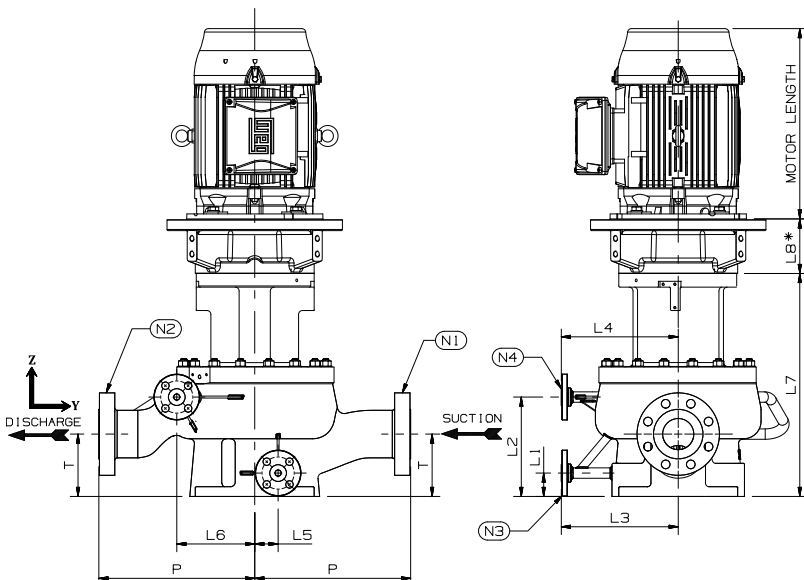

* For full dimensional details see HMD Drawing X9751 which is available on request

Do not use for installation purposes
Dimensions are for guidance only

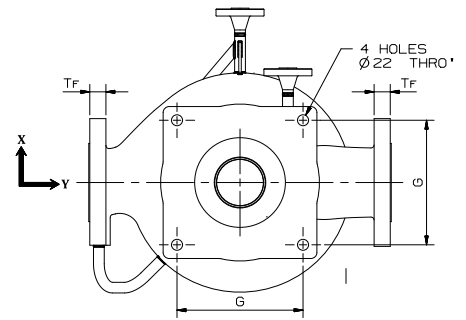

Frame 1 – Dimensions (mm)

PUMP	L6	T	P	G
20E – 2 x 2 x 6	435	125	265	200
20F – 2 x 2 x 8	445	125	265	200
30E – 3 x 3 x 6H	475	160	300	250
40F – 4 x 4 x 8H	564	224	300	250

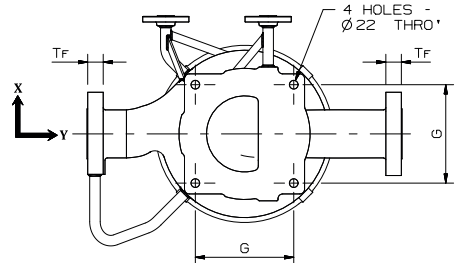

Frame 2 – Dimensions (mm)

PUMP	L7	T	P	G
30G – 3 x 3 x 10	572	160	400	250
40G – 4 x 4 x 10	647	224	400	250
50F – 6 x 6 x 8H	707	250	355	250
50G – 6 x 6 x 10H	683	250	400	250
60F – 8 x 8 x 8H	760	300	375	280

Construction of GSPV pumps

The GSPV range comprises of pumps based on the Sundyne HMD Kontro GSP drive, built to API 685 specification and suitable for heavy-duty applications.

As an overhung, rigidly coupled vertical inline pump it is classified as an OH4 type.

The casings of the GSPV pumps enable the pumps to be line mounted vertically and a flanged vent connection through the casing enables the product lubricated bearings of the GSPV pump to be primed prior to pump rotation.

Dimensionally the range conforms to BS4082 and the suction, discharge nozzles and holding down bolt locations and dimensions are in accordance Part 1 of this standard, thus providing a sealless upgrade solution to existing installations.

With nine hydraulics and a standard design pressure of 580 psi / 40 bar, the GSPV is suitable for a wide range of applications.

The large degree of interchangeability within frame sizes provides commonality so minimising the size of the spare parts inventory and associated costs.

The pump is completely self-draining and conforms to API 685 for sealless pumps and relevant API 610 requirements which ensures safe, leak free operation.

Efficiency is increased via low operating costs, minimal spares holding and maintenance.

Motors

- IEC – 90 to 250, V1 arrangement (Vertical Orientation, Flange Mounted)
- NEMA – 143 TC to 365 TC/TSC, Type C, Face Mount
- Other motor arrangements (i.e. NEMA D, Flange Mount) are not suitable for GSPV pumps as standard

Pressure Limits

All parts are rated to the pressures shown below at 38°C / 100°F

Flange standard	Design pressure			
	S-5	A-8	D-1	D-2
ANSI B16.5 Class 300	4.0 MPa 580 psi	4.0 MPa 580 psi	4.0 MPa 580 psi	4.0 MPa 580 psi

Component	Hydrostatic test values			
	S-5	A-8	D-1	D-2
Casing Class 300	6.0 MPa 870 psi	6.0 MPa 870 psi	6.0 MPa 870 psi	6.0 MPa 870 psi
Containment Shell (Class 300)	6.0 MPa 870 psi	6.0 MPa 870 psi	6.0 MPa 870 psi	6.0 MPa 870 psi

Temperature Limits

S-5	A-8	D-1	D-2
-29°C to 205°C (-20°F to 400°F)	-100°C to 205°C (-148°F to 400°F)	-40°C to 205°C (-40°F to 400°F)	-40°C to 205°C (-40°F to 400°F)

Sundyne Headquarters:

Sundyne, LLC

14845 West 64th Avenue
Arvada, Colorado 80007
USA
1-866-Sundyne
Phone: 1 303 425 0800
Fax: 1 303 940 2911
www.sundyne.com

Sundyne United Kingdom:

Sundyne HMD Kontro Sealless Pumps

Marshall Road
Hampden Park Industrial Estate
Eastbourne East Sussex, BN22 9AN
United Kingdom
Phone: +44 (0)1323 452000
Fax: +44 (0)1323 503369

Sundyne China:

Sundyne Industrial Equipment (Tianjin) Company Limited

Building 1, No. 879 Shen Fu Road
XinZhuang Industrial Zone
Min Hang District
Shanghai, China 201108
Phone: +86 21 5055 5005
Fax: +86 21 5442 5265

Sundyne France:

Sundyne International S.A.

13-15, Bld. Eiffel - B.P. 30
21604 Longvic Cedex
France
Phone: +33 (0)3 80 38 33 00
Fax: +33 (0)3 80 38 33 66

Sundyne Spain:

Sundyne Marelli Bombas, S.R.L.

Ctra. Madrid-Toledo, Km.30.8
45200 Illescas
Toledo, Spain
Phone: +34 925 53 45 00
Fax: +34 925 51 16 00

Worldwide Sales Headquarters

Unit 2 Harvington Business Park
Brampton Road
Hampden Park Industrial Estate
Eastbourne East Sussex, BN22 9BN
United Kingdom
Phone: +44 (0)1323 452125

All information provided is subject to change without notice.

© 2014 Sundyne, LLC
All Rights Reserved. Other logos and trade names are property of their respective owners.

Sundyne HMD Kontro GSPV TP
2.1 09/15 A4 Eng.