

Technical Profile

GS High Pressure

Synchronous magnet drive, hydraulic pumps

Original equipment manufacturers worldwide have discovered the benefits of the HPGS pump when checking the density of fluids passed down a high-pressure pipeline. The pump is used on these skids to take a sample of the fluid out of the main product stream. The sample is then passed through the densitometer, which analyses the fluid, and is afterwards returned to the main pipeline.

The pump's ability to withstand system pressures up to 185 bar / 2680 psi together with its sealless construction, means that the HPGS eliminates the need for expensive callouts, downtime and repairs associated with mechanical seals.

The pumps are offered with a range of Synchronous Magnet Drives rated to match prime mover performance. Prime mover specifications of all denominations can be catered for.

Maximum use has been made of components from our range of ANSI and ISO pumps to ensure optimum interchangeability of parts.

The standard materials of construction are stainless steel with silicon carbide internal bearings.

HMD Kontro



Performance of the GS high pressure range

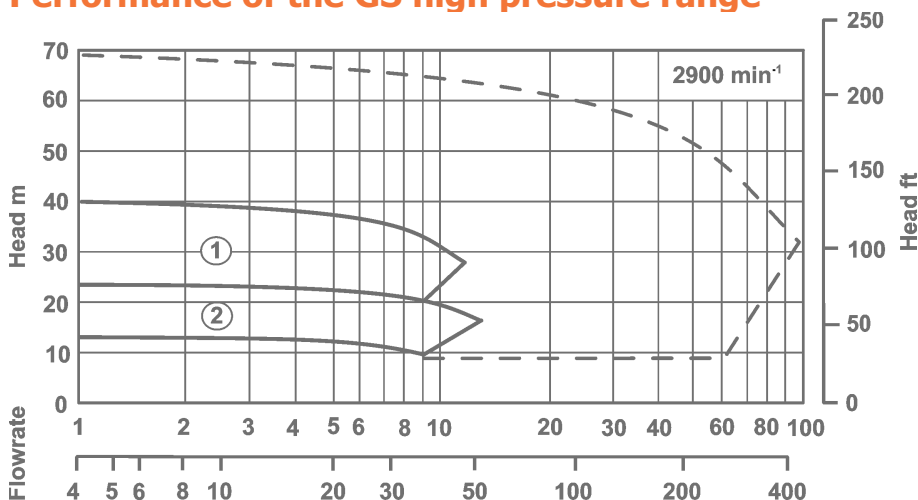

Pump model

	Imperial	Metric
1	1 x 1 x 5	25-25-125
2	1 x 1 x 6	25-25-160

Pumps are available to cover duties within the outer curve and are built on an 'as specified' basis.

Design range limits

The HPGS pump is designed to operate from -40°C up to 205°C, -40°F up to 400°F without the need for any ancillary cooling medium. Maximum design working pressure is 185 bar, 2680 psi

Solids handling capability

The unit is capable of handling solids up to 5% w/w less than 150 microns.

Options

Large range of pump protection.

Key Design Features

- **No seals:** To minimise maintenance, all of the associated costs and eliminate potential leaks.
- **Sealless design:** For total containment, essential for hazardous, aggressive or valuable product.
- **Interchangeability of components:** For maximum convenience and reduced stock holding, operator training etc.
- **High efficiency wet end:** To benefit maximum flow / head coverage.
- **Wide choice of materials:** To allow a choice of various metals in the construction of your pump.
- **Casing gasket fully confined:** So eliminating risk of blowout.
- **Universal connection options:** So that suction and discharge flange connections can be configured to your exact requirements.
- **Modular rotating element cartridge:** Providing the most efficient way to perform replacements and manage your spare part inventory.

Benefits of HPGS pump range

- Sealless design for total product containment.
- Ideal in petrochemical and site utilities.
- Modular / Interchangeable high efficiency wet end.
- Provide maximum flow/head coverage across all product ranges.
- High efficiency magnetic couplings.
- Various metallic materials of construction available on request.
- System pressures up to 185 bar 2680 psi.
- Ideal sampling unit for densitometer applications.

Construction of HPGS range

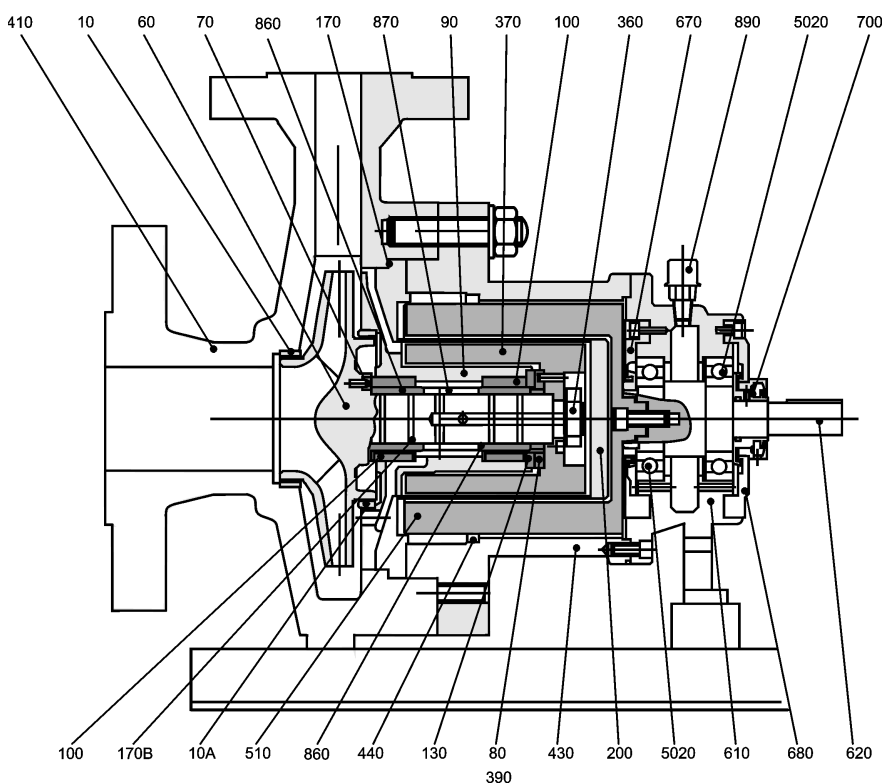

10	Neck Ring (Front)	Stainless Steel
10A	Neck Ring (Back)	Stainless Steel
50	Coupling Washer	Stainless Steel
60	Impeller	Stainless Steel
70	Front Thrust Washer	Alpha SiC
80	Back Thrust Washer	Alpha SiC
90	Bush Holder (150°C/300°F)	Stainless Steel
100	Bush	Alpha SiC
130	Thrust Pad	Alpha SiC
170	Casing Gasket	SS / Graphite
170B	'O' Ring	Viton A
200	Containment Shroud/Shell	SS / Alloy 625
360	Coupling Nut	Stainless Steel
370	Inner Magnet Ring	Stainless Steel
390	Support Gasket	Graphite & Nickel
410	Casing	Stainless Steel
430	Coupling Housing	SG Iron
440	Bump Ring	Phosphor Bronze
510	Outer Magnet Ring	Carbon Steel
610	Bearing Housing	SG Iron
620	Drive Shaft	Carbon Steel
670	Front Cap	Carbon Steel
680	Back Cap	Carbon Steel
700	Labyrinth Seal (Kit)	Brass
860	Shaft Sleeve	Alpha SiC8
70	Shaft Sleeve Spacer	Stainless Steel
890	Breather	Stainless Steel
5020	Race	Steel

Separate mounted model shown

Flanges and Connections

Casing

Suction and discharge flanges are designed in accordance with the following relevant standards:

ANSI B16.5 Class 150	Machined with 1.5mm (0.06") high raised face having a continuous spiral groove.
ANSI B16.5 Class 600	Machined with 6.35mm (0.25") high raised face having a continuous spiral groove.
ANSI B16.5 Class 900	Machined with 6.35mm (0.25") high raised face having a continuous spiral groove.
ANSI B16.5 Class 1500	Class 1500 flanges are also available, but maximum pressure will remain as ANSI Class 900 flange.

Flange Loadings

Allowable flange loadings imposed by pipework are in accordance with Table 4 of API 685 2nd edition and exceed the values in ANSI 5199 Annex C.

Drain Connections

There are no drain options available for these pumps.

Gauge Connections:

No provision for gauge connections has been made on this range of pumps.

Dimensions of HPGS range (close coupled)

Dimensions are for guidance only

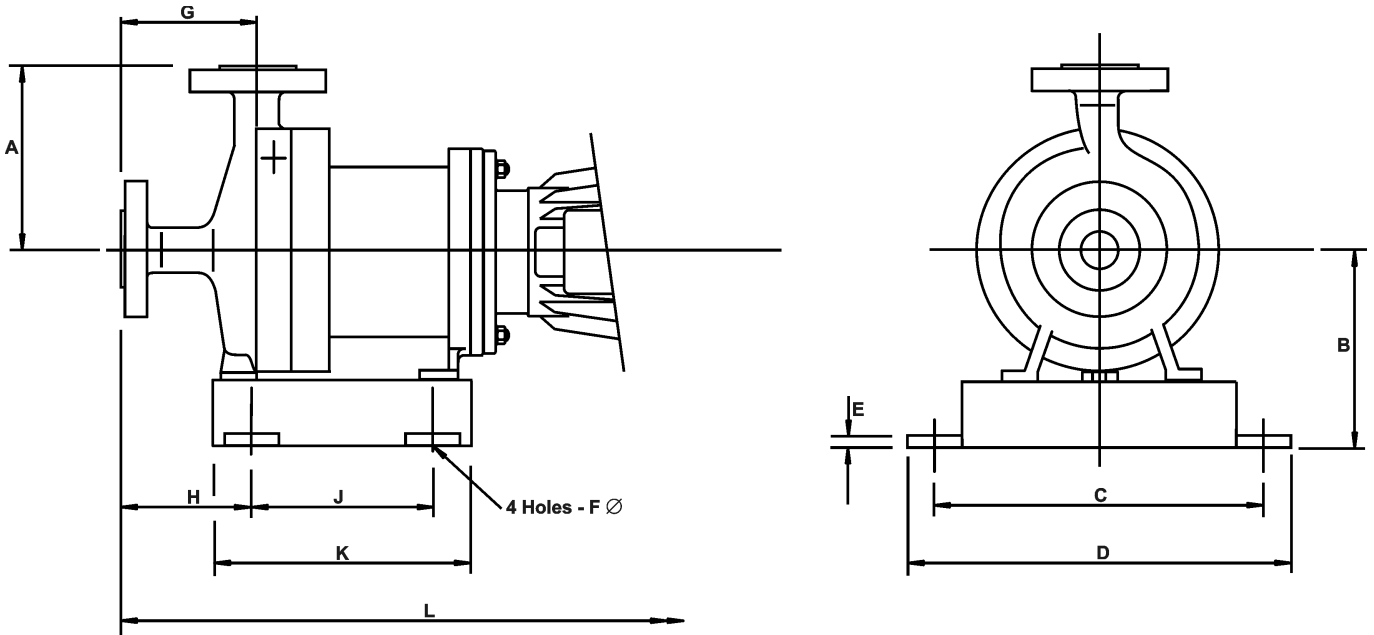

Pump size	A	B	C	D	E	F	G	H	J	K	Motor Frame	L
1x1x5	200/7.9"	239/9.4"	350/13.8"	400/15.7"	12/0.5"	14/0.55"	155/6.1"	106/4.2"	230/9.1"	306/12"	80-90	620/24.4"
1x1x6	200/7.9"	239/9.4"	350/13.8"	400/15.7"	12/0.5"	14/0.55"	155/6.1"	106/4.2"	230/9.1"	306/12"	100-112	685/27"
											132	773/30.4"
25-25-125	200/7.9"	239/9.4"	350/13.8"	400/15.7"	12/0.5"	14/0.55"	155/6.1"	106/4.2"	230/9.1"	306/12"	160	918/36.1"
25-25-160	200/7.9"	239/9.4"	350/13.8"	400/15.7"	12/0.5"	14/0.55"	155/6.1"	106/4.2"	230/9.1"	306/12"	143-145	610/24"
											182-184	686/27"
											213-215	762/30"
											254-256	914/36"

Dimensions shown are metric / imperial (inches).

Range capabilities

Model	Head	Flow	Design Temperature	Design Pressure	Viscosity cSt	Mounting
1x1x5	24 m 78 ft	11 m ³ /h 48 USgpm	-40 to 205°C -40 to 400°F	185 bar 2680 psi	200	Close Coupled (CC) Separate Mounted (SM)
1x1x6	40 m 131 ft	10.5 m ³ /h 46 USgpm	-40 to 205°C -40 to 400°F	185 bar 2680 psi	200	Close Coupled (CC) Separate Mounted (SM)

Pressure Limits

All parts are to be rated to the pressures shown below at 38°C / 100°F

Flange standard

	316 St St
ANSI B16.5 Class 300	4.96 MPa 720 psi
ANSI B16.5 Class 600	9.93 MPa 1440 psi
ANSI B16.5 Class 900	14.89 MPa 2160 psi

Component Hydrostatic test values

	316 St St
Casing (ANSI 300)	7.44 MPa 1080 psi
Casing (ANSI 600)	14.89 MPa 2160 psi
Casing (ANSI 900)	22.34 MPa 3240 psi

Temperature limits

Standard Range	-40°C to 150°C / -40°F to 300°F
Option	205°C / 400°F

For sub zero temperatures a suitable sealing compound (Loctite Multi Gasket or similar) is used to prevent the ingress of moisture into the coupling housing between the containment shroud / shell and motor adaptor assembly interface.

Sundyne Headquarters:

Sundyne, LLC

14845 West 64th Avenue
Arvada, Colorado 80007
USA
1-866-Sundyne
Phone: 1 303 425 0800
Fax: 1 303 940 2911
www.sundyne.com

Sundyne United Kingdom:

Sundyne HMD Kontro Sealless Pumps

Marshall Road
Hampden Park Industrial Estate
Eastbourne, East Sussex, BN22 9AN
United Kingdom
Phone: +44 (0)1323 452000
Fax: +44 (0)1323 503369

Sundyne China:

Sundyne Industrial Equipment (Tianjin) Company Limited

Building 1, No. 879 Shen Fu Road
XinZhuang Industrial Zone
Min Hang District
Shanghai, China 201108
Phone: +86 21 5055 5005
Fax: +86 21 5442 5265

Sundyne France:

Sundyne International S.A.

13-15, Bld. Eiffel - B.P. 30
21604 Longvic Cedex
France
Phone: +33 (0)3 80 38 33 00
Fax: +33 (0)3 80 38 33 66

Sundyne Spain:

Sundyne Marelli Bombas, S.R.L.

Ctra. Madrid-Toledo, Km.30.8
45200 Illescas
Toledo, Spain
Phone: +34 925 53 45 00
Fax: +34 925 51 16 00

Worldwide Sales Headquarters

Unit 2 Harvington Business Park
Brampton Road
Hampden Park Industrial Estate
Eastbourne East Sussex, BN22 9BN
United Kingdom
Phone: +44 (0)1323 452125

All information provided is
subject to change without notice.

© 2014 Sundyne, LLC
All Rights Reserved. Other logos
and trade names are property of
their respective owners.

Sundyne HMD Kontro
HPGS 2.0 8/14 A4 Eng.