

THIS DOCUMENT CONTAINS PROPRIETARY INFORMATION OF SUNDYNE CORPORATION. NEITHER RECEIPT NOR POSSESSION THEREOF CONFERS ANY RIGHT TO REPRODUCE, OR USE, OR DISCLOSE, IN WHOLE OR IN PART, ANY SUCH INFORMATION WITHOUT WRITTEN AUTHORIZATION FROM SUNDYNE CORPORATION.

REVISION	
NO	DESCRIPTION
1	REV

UNLESS OTHERWISE SPECIFIED OR APPLICABLE	
1	DIMENSIONS IN INCHES (mm)
2	ALL PIPING CONN. ± 1/4"
3	WEIGHTS: PUMP 260 LBS/118 KG GEARBOX 110 LBS/ 50 KG MISC 100 LBS/ 45 KG MOTOR LBS/ KG
TOTAL	
4	NOTE: THIS PROPOSAL DWG IS INTENDED FOR USE OF EQUIPMENT AS SPECIFIED IN "TITLE BLOCK" ONLY. OTHER EQUIPMENT SUCH AS MOTOR, GAUGES AND MATERIAL WILL BE SPECIFIED AND DIMENSIONED AS REQUIRED ON THE CUSTOMER OUTLINE DRAWING.

MAXIMUM ALLOWABLE FORCES AND MOMENTS ON FLANGES OF SUNDYNE UNITS

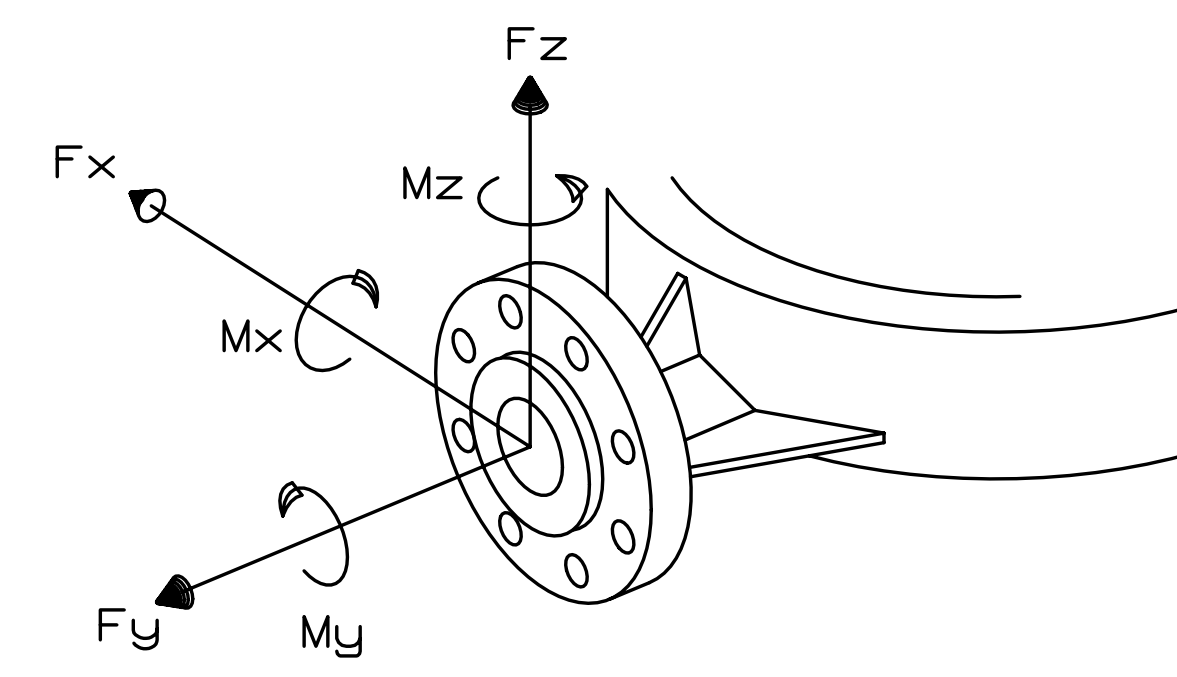

PUMP MODELS LMV-311,322,331,801,802,806;BMP-311,331

FLANGES	FORCES = LBF			MOMENTS = FT-LBF		
	Fx	Fy	Fz	Mx	My	Mz
SUCTION 3"	480	600	400	1400	700	1060
DISCHARGE 2"	320	400	260	680	340	520

FLANGES	FORCES = NEWTON			MOMENTS = NEWTON METER		
	Fx	Fy	Fz	Mx	My	Mz
SUCTION 3"	2135	2669	1779	1898	949	1437
DISCHARGE 2"	1423	1779	1157	922	461	705

THESE VALUES DEVELOPED FROM FORCES AND MOMENTS LIMITS AS ESTABLISHED IN API 610, 8TH EDITION

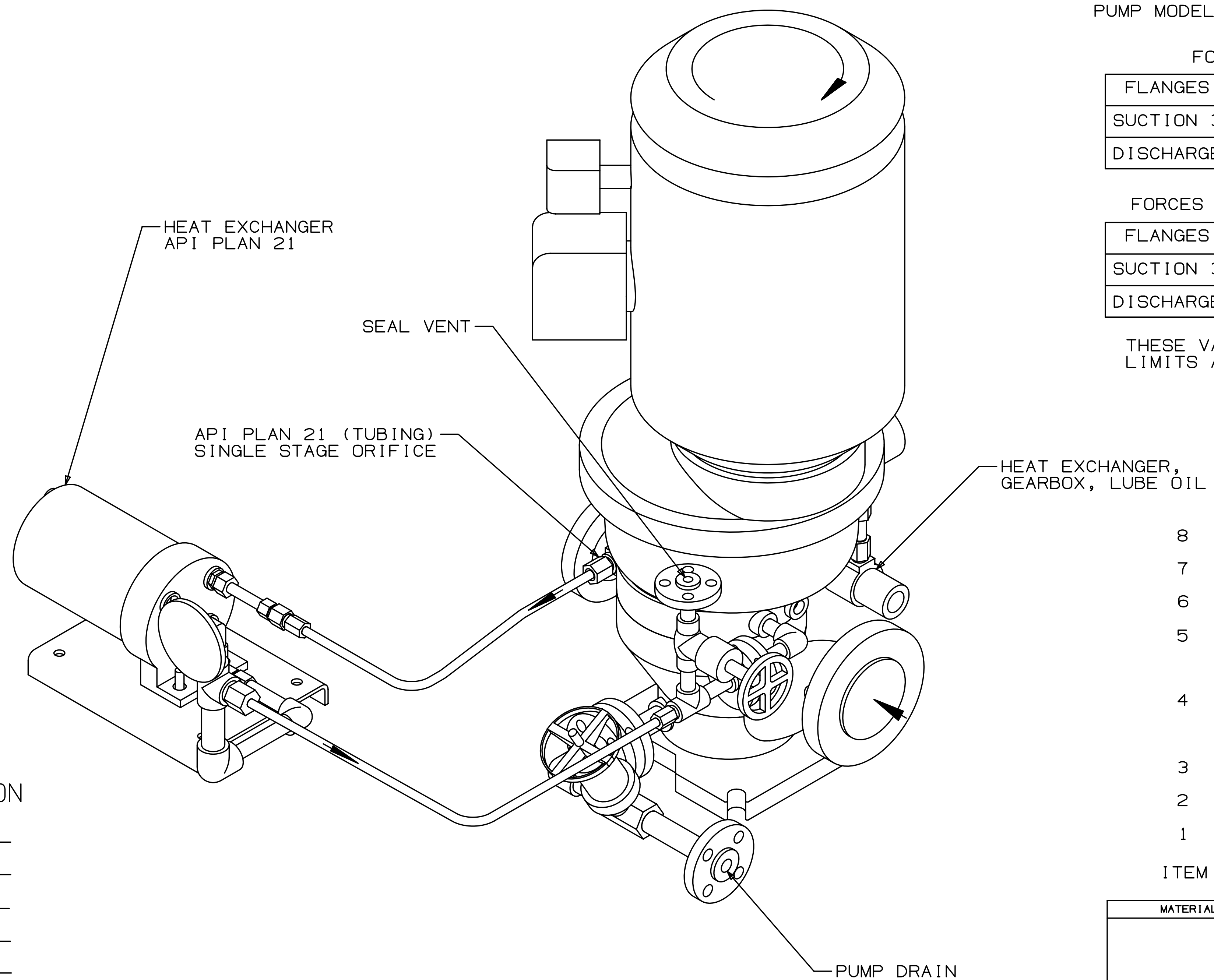

- 8 GAUGE, TEMPERATURE, 2-1/2" DIAL
- 7 HEAT EXCHANGER, 2 X 9, 1 PASS
- 6 HEAT EXCHANGER
- 5 VALVE, GATE #12401, 1/2" SW, BOLTED BONNET, OS&Y, CL 800, 1975 PSI @ 100°F
- 4 VALVE, GATE, VOGT #12401, 1"SW, BOLTED BONNET, OS&Y, CL 800, 1975 PSI @ 100°F
- 3 GAUGE, PRESSURE, 2-1/2" DIAL
- 2 GAUGE, TEMPERATURE, 5" DIAL
- 1 ORIFICE, SINGLE STAGE

CUSTOMER INFORMATION

CUSTOMER : _____
 INQUIRY/P.O. NO. : _____
 QUOTE NO. : _____
 ITEM NO. : _____
 SALES OFFICE : _____
 DATE : _____

ITEM	DESCRIPTION
MATERIAL	DWN L. WEBER 11/15/01
PROJ	
MFG	
QLTY	
LMV-322 GEARBOX HX, API PLAN 21 (TUBING), VENT & DRAIN	
SCALE 1/8"	WT:ACTL
SIZE D	REV
PR21AB02	
SHEET 1 OF 2	

MODEL LMV322

THIS DOCUMENT CONTAINS PROPRIETARY INFORMATION OF SUNDYNE CORPORATION. NEITHER RECEIPT NOR POSSESSION THEREOF CONFERS ANY RIGHT TO REPRODUCE, OR USE, OR DISCLOSE, IN WHOLE OR IN PART, ANY SUCH INFORMATION WITHOUT WRITTEN AUTHORIZATION FROM SUNDYNE CORPORATION.

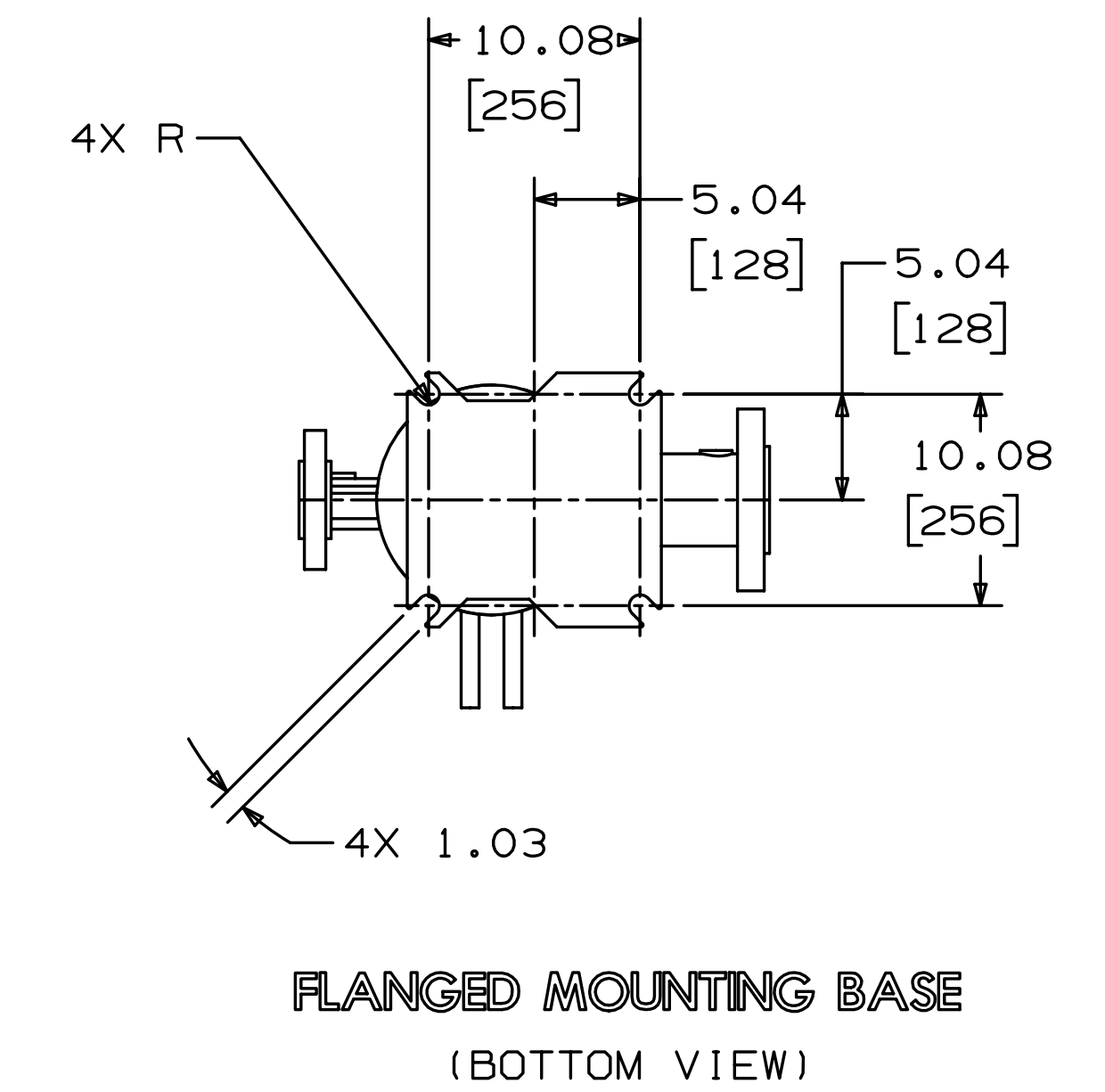
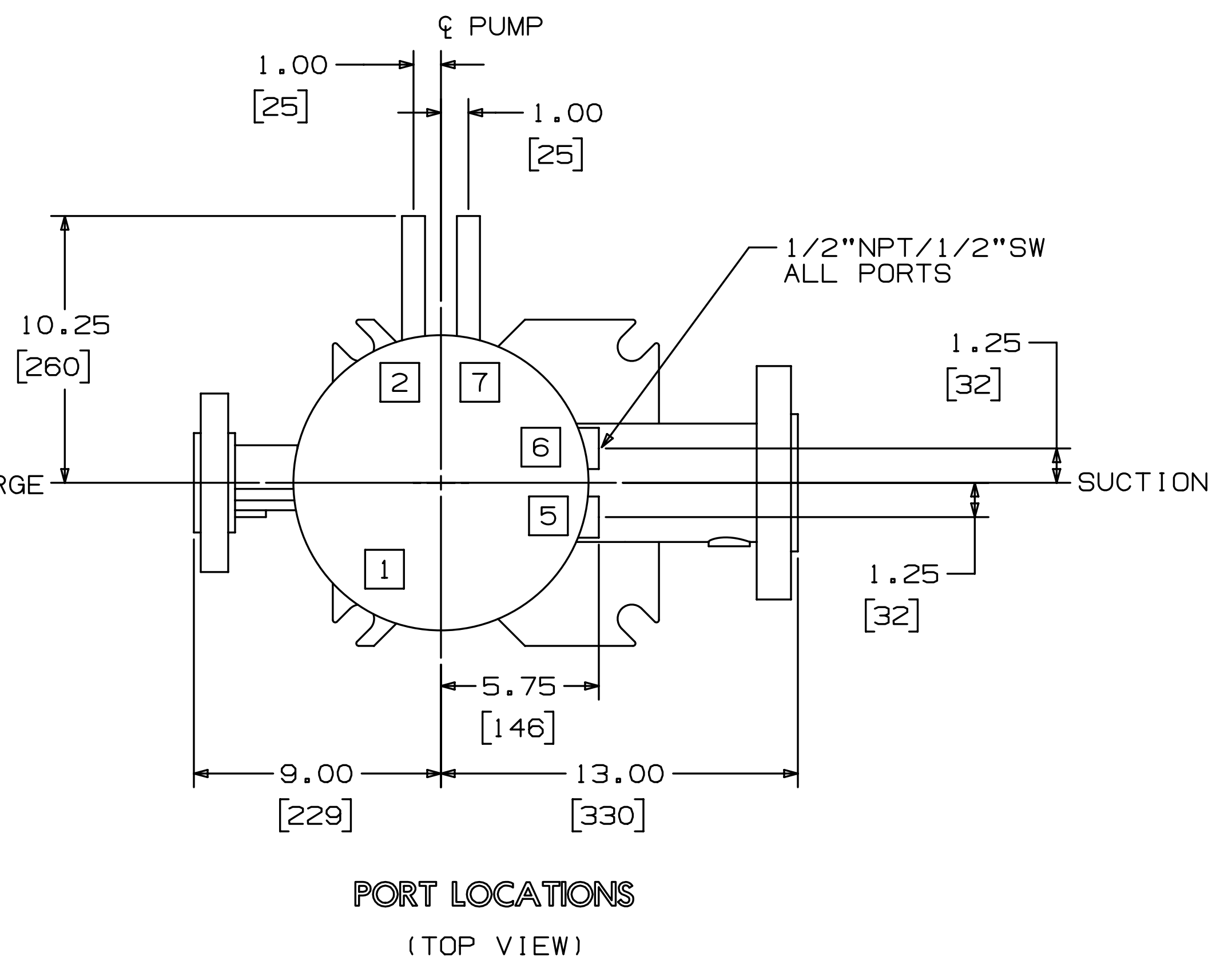
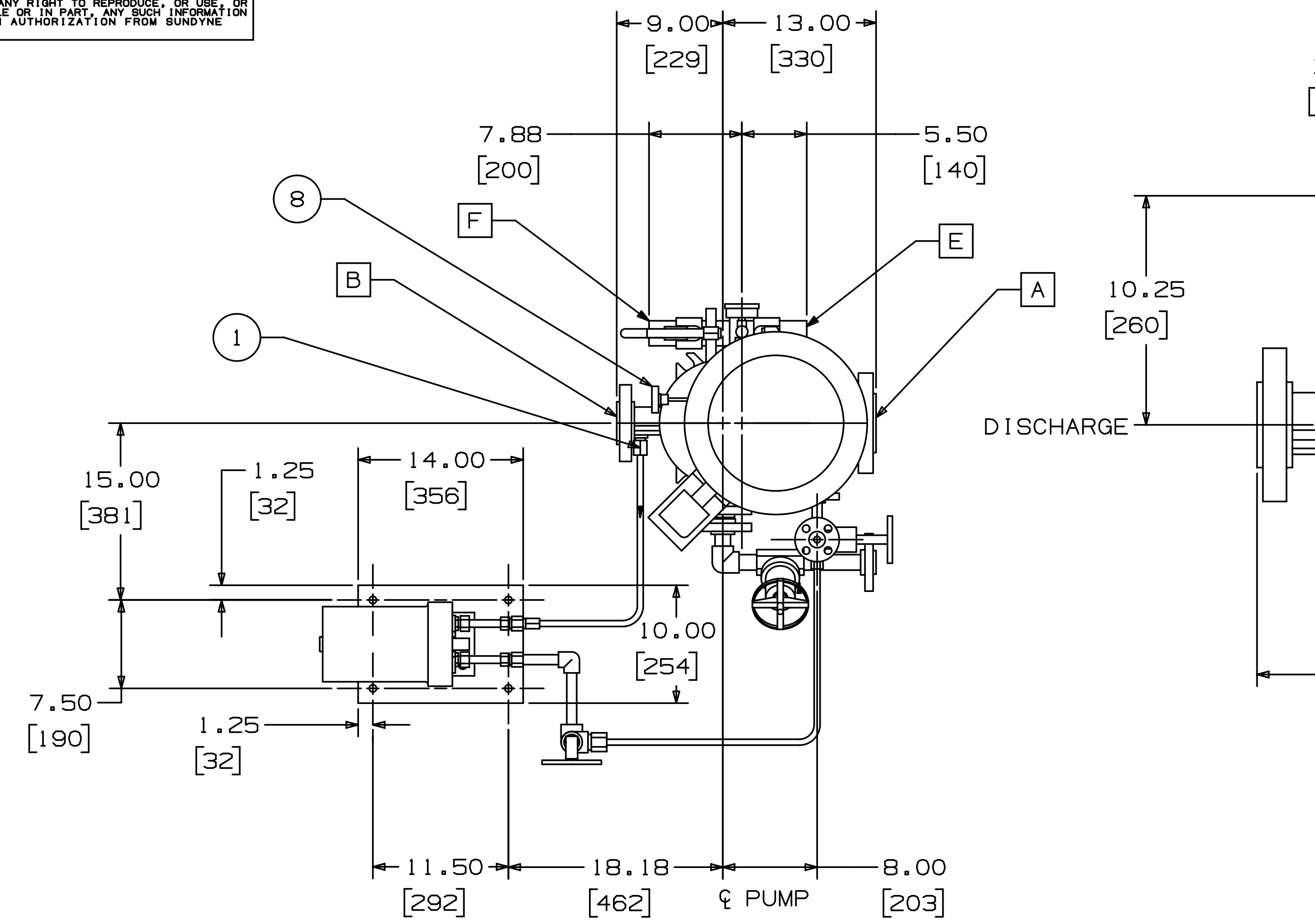

CUSTOMER CONNECTIONS

- A PUMP SUCTION
3-600#RF FLANGE
- B PUMP DISCHARGE
2-600#RF FLANGE
- C PUMP CASE DRAIN
1-600#RF FLANGE
- D PUMP SEAL VENT
1/2"-600#RF FLANGE
- E HEAT EXCHANGER, GEARBOX
COOLANT IN
1" NPT
- F HEAT EXCHANGER, GEARBOX
COOLANT OUT
1" NPT
- G HEAT EXCHANGER
API PLAN 21
COOLANT IN
3/4" NPT
- H HEAT EXCHANGER
API PLAN 21
COOLANT OUT
3/4" NPT

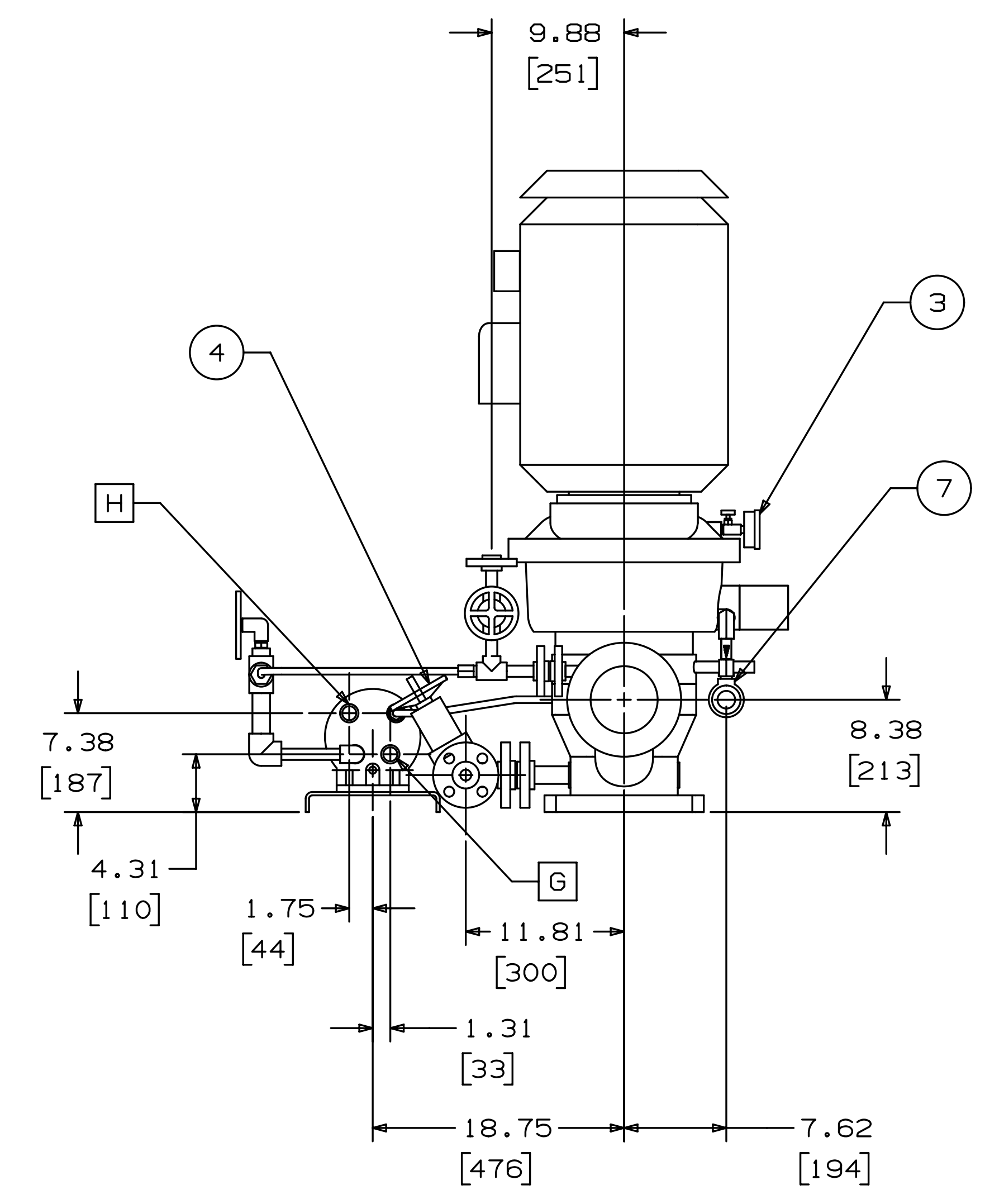
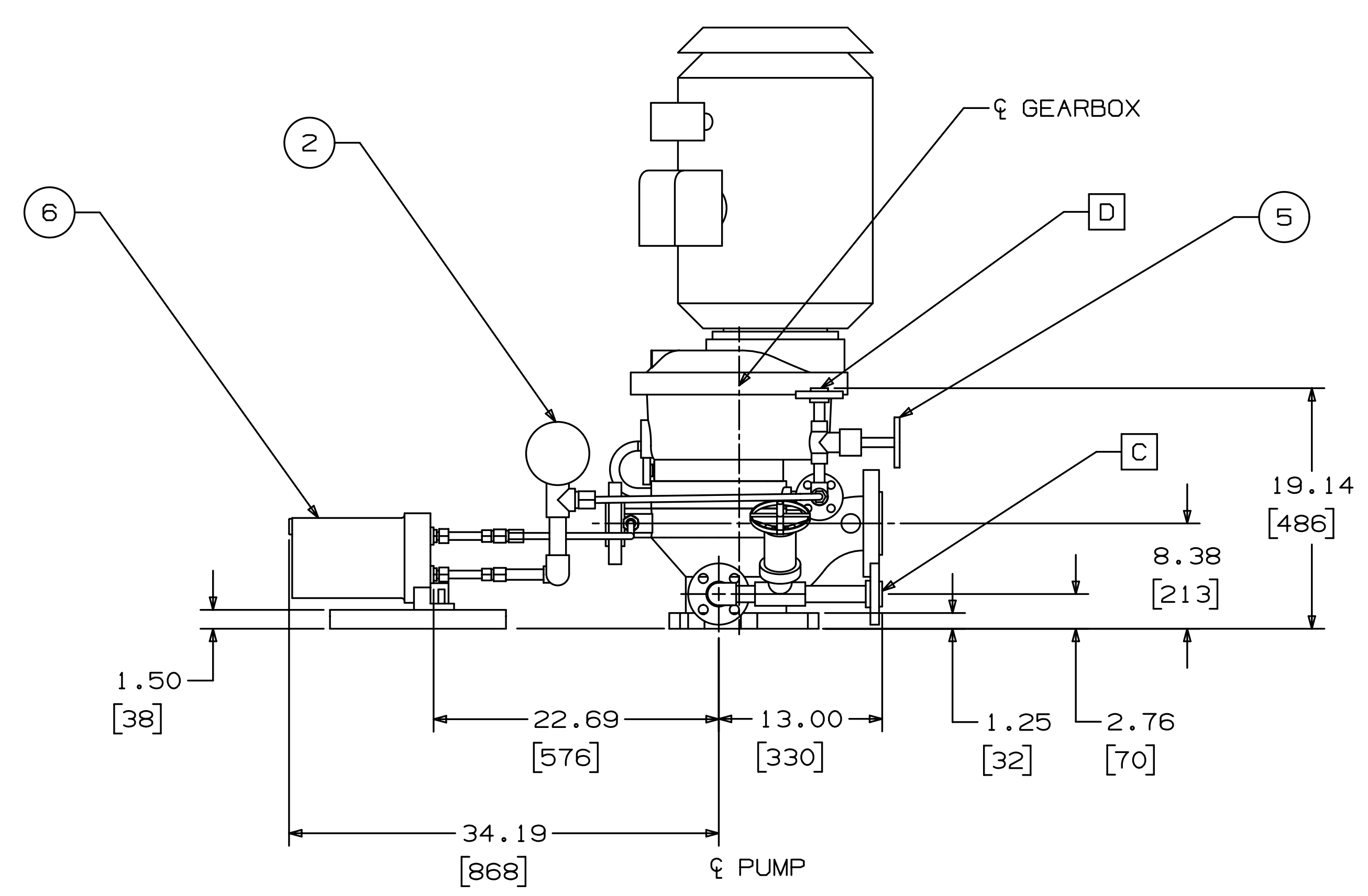

LMV-322 GEARBOX HX, API PLAN 21 (TUBING), VENT & DRAIN			
SIZE D	PR21AB02	REV	
SCALE 1/8	WT:ACTL	CALC	SHEET 2 OF 2