



*OH3 or OH5 Direct Drive  
API 610 Centrifugal Pumps  
Specify the ideal pump to  
optimize your most demanding  
process condition.*

LMV-801



LMV-801S



LMV-801CS



LMV-803Lr



LMV-802



LMV-806



**RELIABILITY  
REALIZED.™**

# Innovation In Pump Technology

## API 610, OH3 and OH5 Direct Drive Process Industry Pumps

Sundyne API 610, OH3 and OH5 direct drive pumps are known for their high-head, low-flow capabilities ideally suited for multiple applications throughout the process industries. Each pump in the series features a single-stage centrifugal design with single, double or tandem seal arrangements for reliable service in the most difficult applications.

## Pump Designs Specifically for the Process Industries

Each pump in the API 610, OH3 and OH5 direct drive family is optimized for different flow rates and head requirements that are demanded by applications in a wide range of upstream oil and gas, midstream gas processes and downstream hydrocarbon/refining processes, chemical, petrochemical and general industrial processes.

## Best Design Choice for Maximum Reliability

The Sundyne API 610, direct drive family of pumps are vertical inline, single stage, overhung pumps that are either a close coupled design (OH5) or features a separate bearing bracket (OH3) with a flexible shaft coupling to accommodate multiple motor options. Each Sundyne direct drive pump is designed specifically to handle every application at its best efficiency point and maximize reliability and tolerance to system variations. Installation and maintenance are typically easily implemented.



◀ Sundyne OH3 pumps are designed for suction pressures up to 1000 PSIG – Nema or IEC motor.



▲ The Sundyne LMV-806 OH5 has been providing years of proven reliability in de-ethanizer booster service for this Oklahoma gas plant.

## Key Innovative Features Drive Our Competitive Advantage

Customers around the world depend on Sundyne to build the equipment they require to drive productivity, and our robust engineered solutions deliver the level of quality and reliability they demand. With a range of comprehensive features, service and support, Sundyne is committed to fulfilling our customer's long-term needs.

### Optimized Efficiency With Low Specific-Speed Hydraulics

Sundyne LMV series pumps boast diffuser style hydraulics to optimize efficiency in low specific-speed applications. Efficiency up to 60%.

### Low NPSHr As Low As 5 feet (1.5m)

Sundyne inducers are designed to reduce your NPSHr considerably, thus eliminating the need for costly design requirements, such as elevated suction vessels, boost pumps or installation below grade.

### Flexible Mechanical Seal and Sealless Configurations

Sundyne direct drive pumps can be configured with single, double or tandem seal arrangements, which can be easily converted in the field. With the recent introduction of the LMV-801S sealless magnetic drive, any LMV-801 sealed pump can be converted to an ultra-reliable, leak-free sealless configuration.

### Materials of Construction

The Sundyne direct drive line of pumps are available with a broad variety of metallurgies and machineable alloys, such as:

- Carbon Steel
- Hastelloy B
- 316SS
- Monel
- Titanium

### Engineered Best Efficiency Point

We size your pump so rated point is Best Efficiency Point (B.E.P.), providing an ultra-efficient, reliable flow rate.

# BEP

- Compact Footprint For Modular Design
- Simple By Design
- Standard Or Custom Engineered Options
- Worldwide Support Network
- Seal Configurations Available: Single, Double, Tandem, Sealless OR API 682 Cartridge Seal



- Solids Range: 0.015" (0.381mm), 400 microns
- Mounting Configurations: Vertical
- Number of Available Hydraulics: Numerous
- Available Inducer: Yes
- Available Flanges: 300# RF, 600# RF, 900# RF, RTJ





### Industries

- Upstream Oil & Gas
- Midstream Gas Process
- Downstream Refining
- Downstream Petrochemical
- Downstream Chemical
- General Industrial

### Applications

Sundyne direct drive API pumps are suitable for use in applications across the process industries like:

- Transfer
- Recycle
- Bottoms
- Pipeline boost
- Boiler Feed Water
- Desuperheating
- Condensate
- Fuel Feed
- Seal Water
- Inorganic Acids
- High Pressure Wash
- Cryogenic Services
- Offshore Platform Services
- Charge / Reactor Feed



Handles high suction pressure above 500 PSI

# NPSH

## ADVANTAGES

► Sundyne inducer options reduce NPSHr considerably and often eliminates the need for costly design requirements, such as elevated suction vessels and boost pumps.

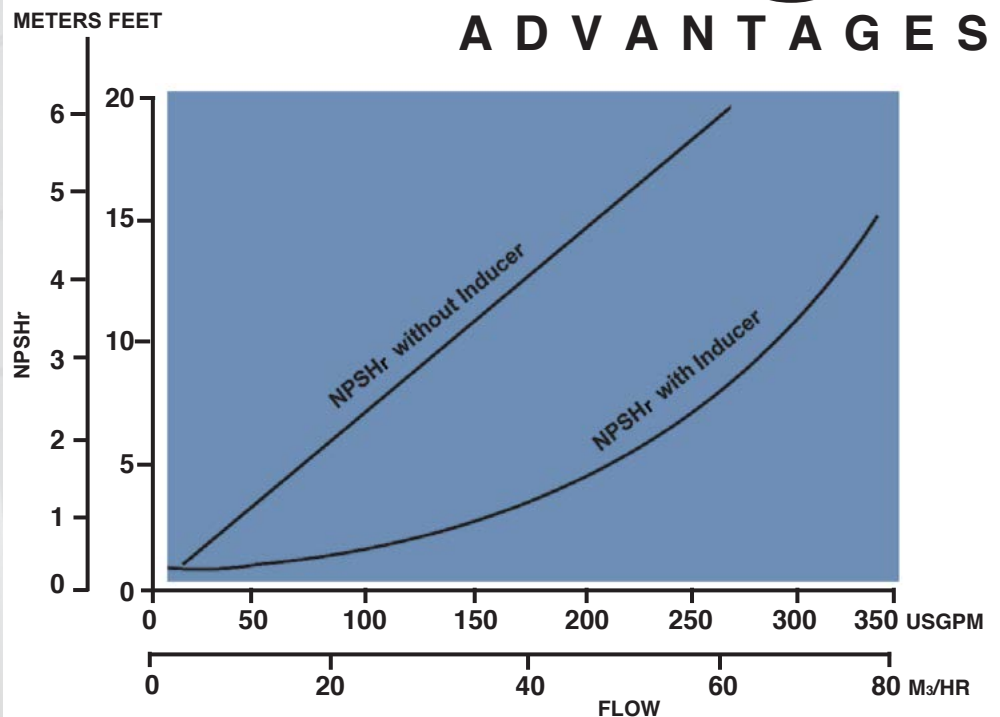

The OH3 bearing frame may be bolted directly on top of the sealhousing. This option provides added driver flexibility, such as the use of standard NEMA or IEC shaft electric motors and steam turbines. The unique piloted mounting flange eliminates the need to align the pump and motor, saving valuable installation and maintenance time. The housing has been designed to accommodate a broad range of couplings to suit your specific needs.



The Sundyne LMV-801 API 610, is a direct drive vertical inline, single stage, overhung impeller centrifugal pump in a standard OH5 configuration. OH3 when used with the bearing frame option. This model delivers:

**Flows to 380 gpm (86 m<sup>3</sup>/hr)**  
**Heads to 720 ft (219 m)**

**This heavy duty API 610 pump is ideal for Hydrocarbon processing, including Refining and Petrochemical, Chemical processing and midstream natural gas.**

Obtaining a re-rate or removing the diffuser while the pump case remains in place has never been easier.

# LMV-801

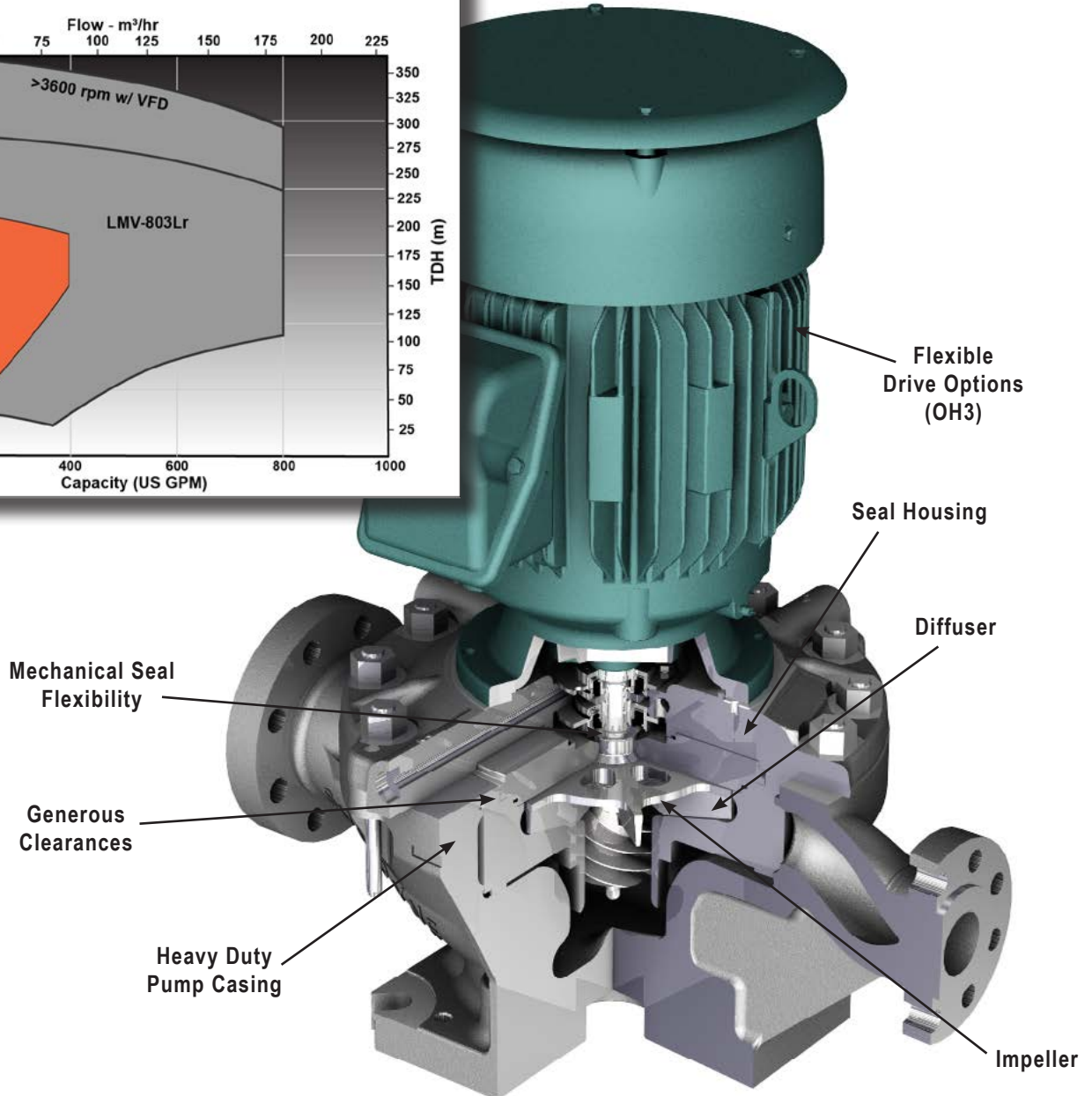
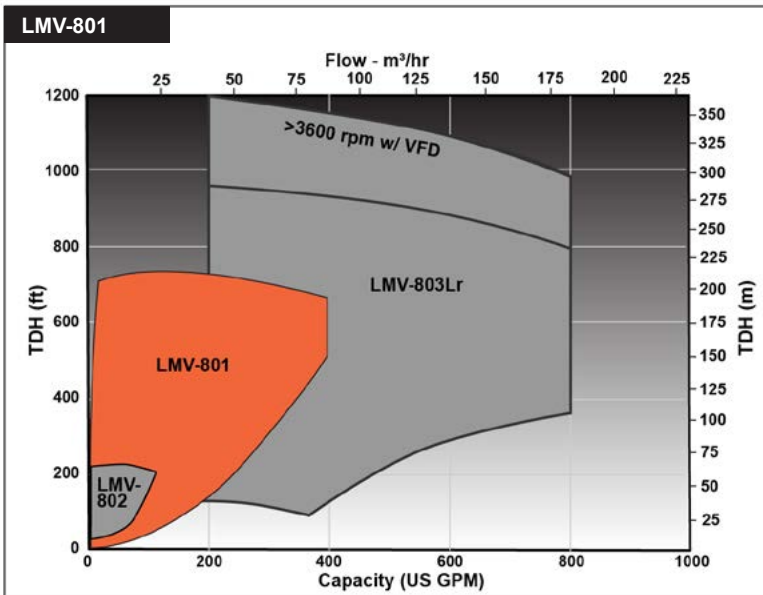

# Ideally Suited for High-

The Sundyne LMV-801S is an API 685, vertical inline, single stage, overhung sealless magnetic drive pump that is ideally suited for high-head, low-flow applications, commonly found in today's refinery processing, chemical processing and midstream industries. The LMV-801S is part of Sundyne direct-drive line of pumps that offers reliable performance in a compact vertical design.

## Combining Proven Sundyne Hydraulics with Pioneering Magnetic Drive Technology:

The LMV-801S combines the industry standard hydraulics of the Sundyne direct-drive line of pumps with sealless magnetic drive technology pioneered by Sundyne HMD/Kontro more than 70 years ago. Built to comply with both API-685 and API-610 standards, it's specifically engineered to eliminate emissions and improve personnel safety.

## Worry-Free Conversion:

The LMV-801S is dimensionally interchangeable with the traditional mechanically sealed LMV-801 (OH3/5), and can be easily dropped into existing pipework - making this sealless upgrade possible without the need to modify piping and foundation layouts. Additionally, a plug-in version of the pump is available, enabling customers to swap out the mechanical seal drive end with the new sealless option without disconnecting the existing LMV-801 casing and diffuser from the piping.

## Benefits:

The LMV-801S delivers maximized up-time, reduced maintenance costs and optimized productivity over the lifecycle of the unit. Its sealless magnetic drive design offers no seals that leak, making it safe and reliable for handling hazardous liquids and light hydrocarbons.

The LMV-801S provides the benefits of a sealless pump, the reliability of Sundyne hydraulics all in a compact package.

Dimensionally Interchangeable



*Sealless magnetic drive pump is interchangeable with...*

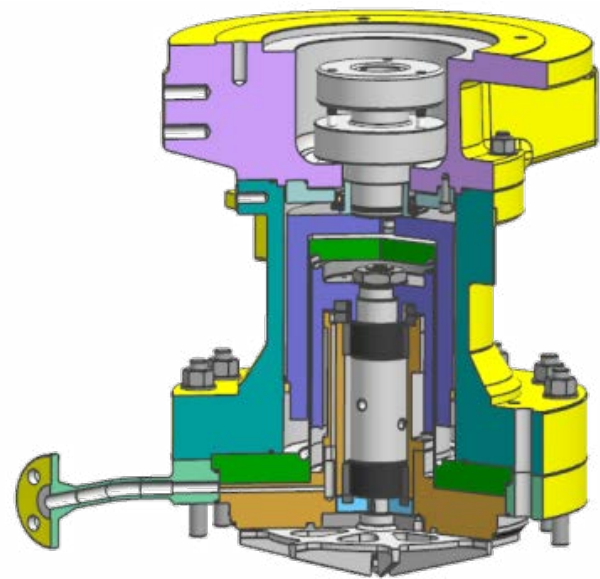

*LMV-801 pump case and your piping.*

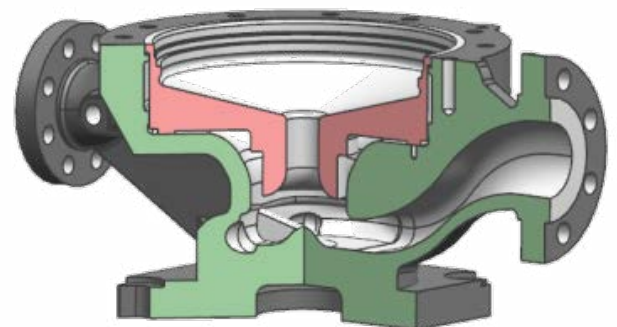



# head, Low-flow Liquids

The LMV-801S is an API 685 vertical inline, single stage, overhung impeller, sealless magnetic direct drive pump. This model delivers:

**Flows to 380 gpm (86 m<sup>3</sup>/hr)**  
**Heads to 720 ft (219 m)**

**Ideal for handling light hydrocarbons in hydrocarbon processing, chemical handling and offshore applications.**

Dimensionally interchangeable with our mechanically sealed LMV-801 model.

A retrofit kit is available to convert the mechanical seal drive end with a new sealless option without disconnecting the existing LMV-801 casing and diffusers from the piping.

## LMV-801S

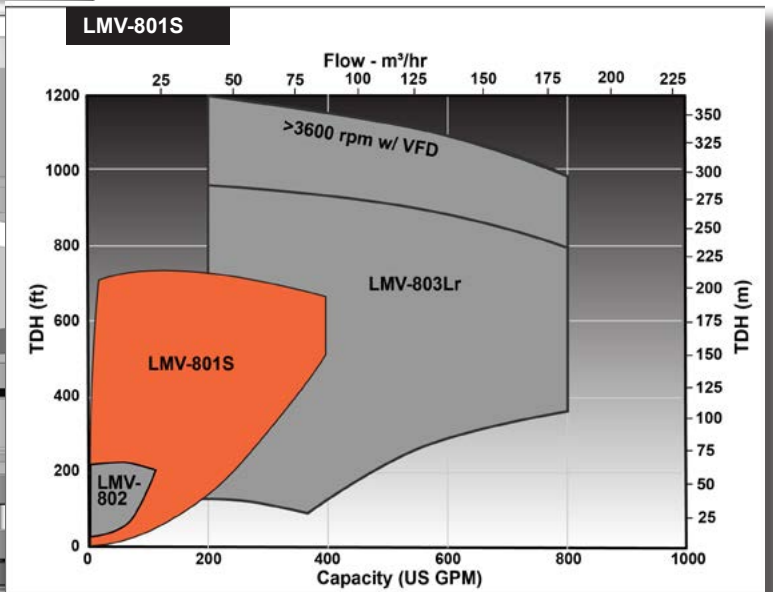
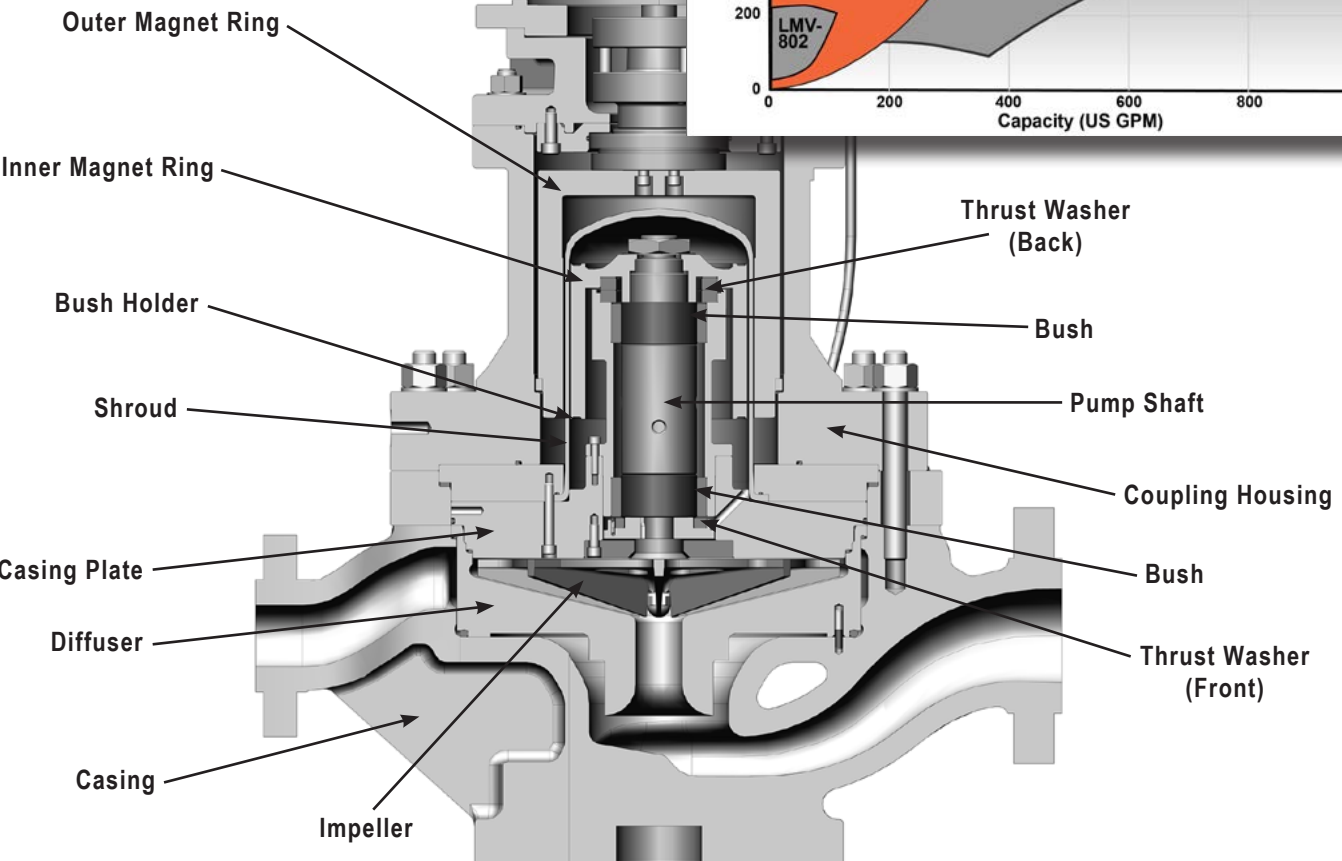

# Single, Double, Tandem HAVE IT YOUR WAY. TODAY.

- Faster, easier, and error-free replacement of pump shaft seals
- The Sundyne LMV-801CS can be installed on any Sundyne LMV-801 without changing the wet end components
- Eliminates premature failures due to improper installation
- Less downtime for maintenance
- Increased durability & reliability with the **API 682 cartridge seal**

The Sundyne LMV-801CS is a direct drive vertical inline, single stage, overhung impeller centrifugal pump with a API 682 cartridge seal in a standard OH3 API 610, configuration. This model delivers:

Flows to 380 gpm (86 m<sup>3</sup>/hr)  
Heads to 720 ft (219 m)

Thousands of reliable Sundyne LMV-801 pumps are utilized in refining, petrochemical and chemical processing facilities. Also, they are commonly utilized in midstream natural gas processing plants and offshore production rigs including FPSO's.

Patent  
Pending:

# LMV-801CS

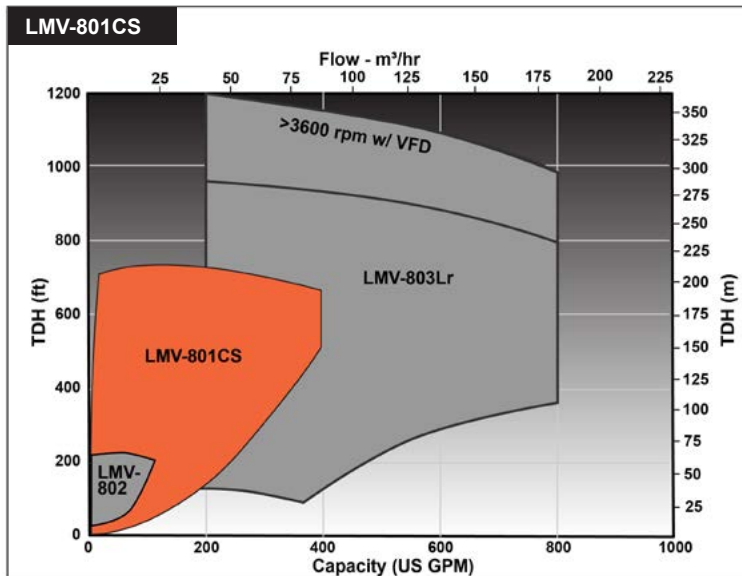

**A Reliable New Feature for  
Faster, Easier, Error-free  
Replacement of Pump  
Shaft seals – Keeping  
You Up and Running.**

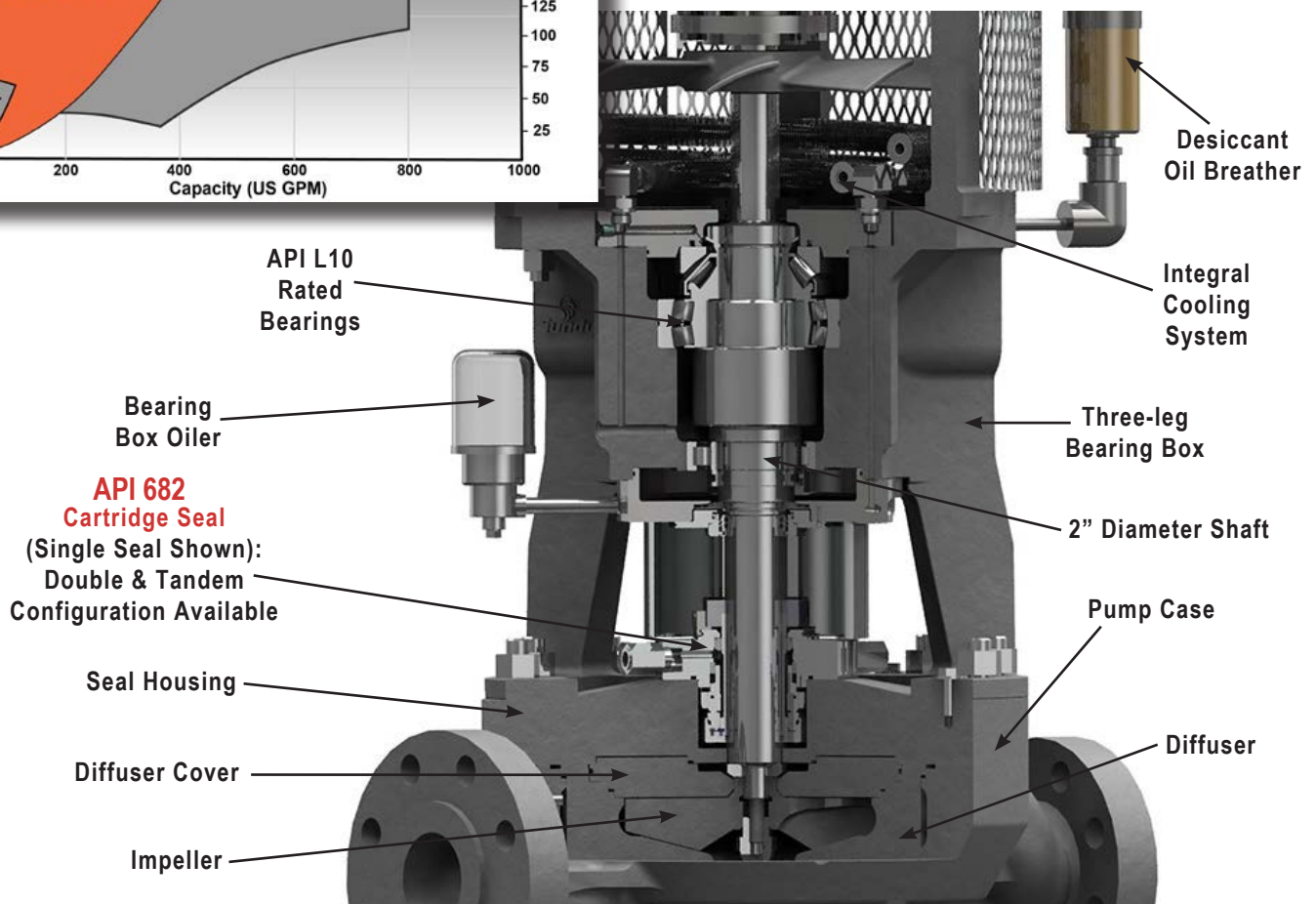



# Reliable & Efficient

The Sundyne LMV-802 is a direct drive vertical inline, single stage, overhung impeller, centrifugal API 610, pump available in OH3 and OH5 configurations. This model delivers:

**Flows to 150 gpm (34 m<sup>3</sup>/hr)  
Heads to 210 ft (64 m)**

**A reliable heavy duty API pump for use in the Hydrocarbon processing and Chemical processing industries.**

## LMV-802

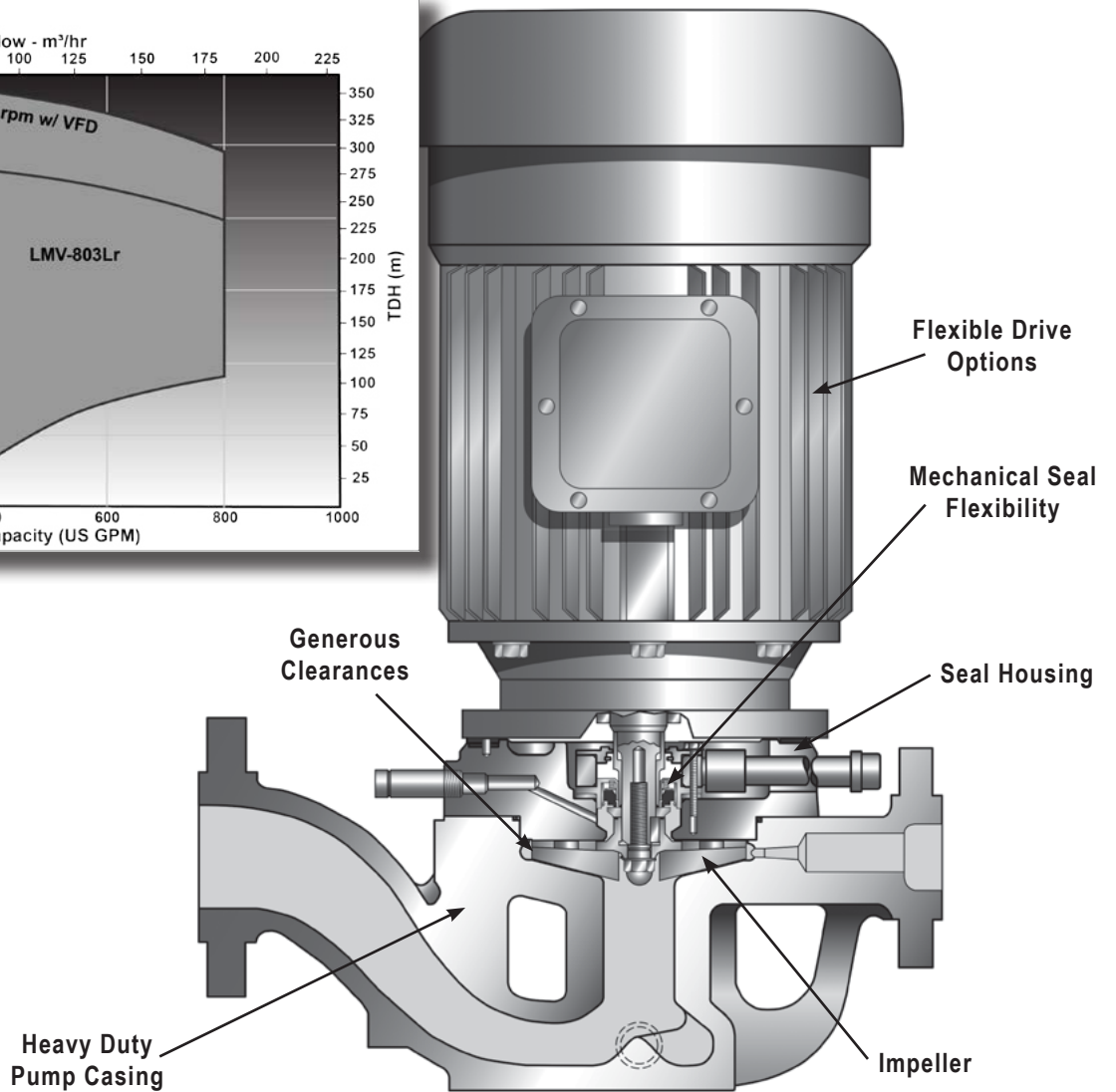
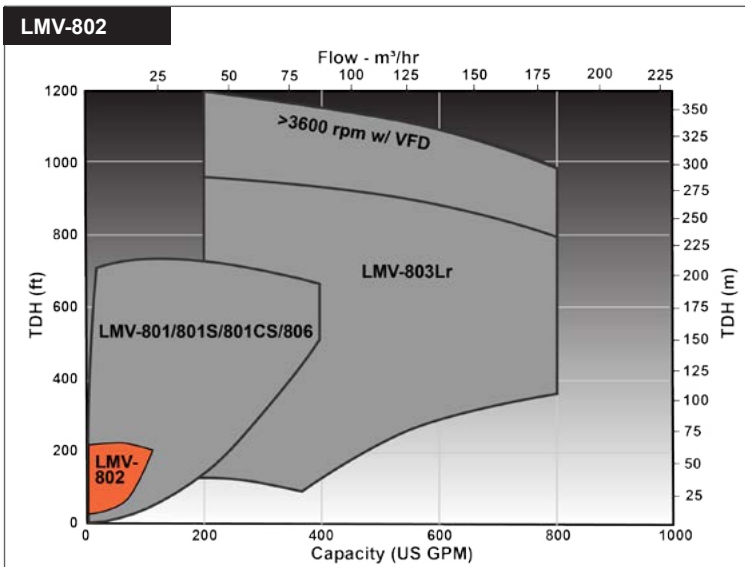

# How Low Can We Go?

The LMV-803Lr is a high flow ultra low NPSHr (5 ft / 1.5 m) direct drive vertical inline, single stage, overhung impeller pump. Featuring Sundyne inducer technology and a backswept impeller, making it possible to reach lower NPSH requirements without risk of cavitation.

Built to comply with OH3 and OH5 standards and fully compliant with API 610 A-8 material guidelines, the LMV-803Lr is available with a robust 6x4 case design that is built to withstand the rigors of high pressure applications.



Flows to 800 gpm (180 m<sup>3</sup>/hr)  
Heads to 1,000 ft (305 m)  
Max Case Work Pressure to 1,000 psig (70 kg/cm<sup>2</sup>)

Ideal for midstream LNG processing, booster / charge, fractionation bottoms and more.

## LMV-803Lr

**A Centrifugal High Flow, Low NPSH Pump. NPSH Less Than 5 FT at 500 GPM!**

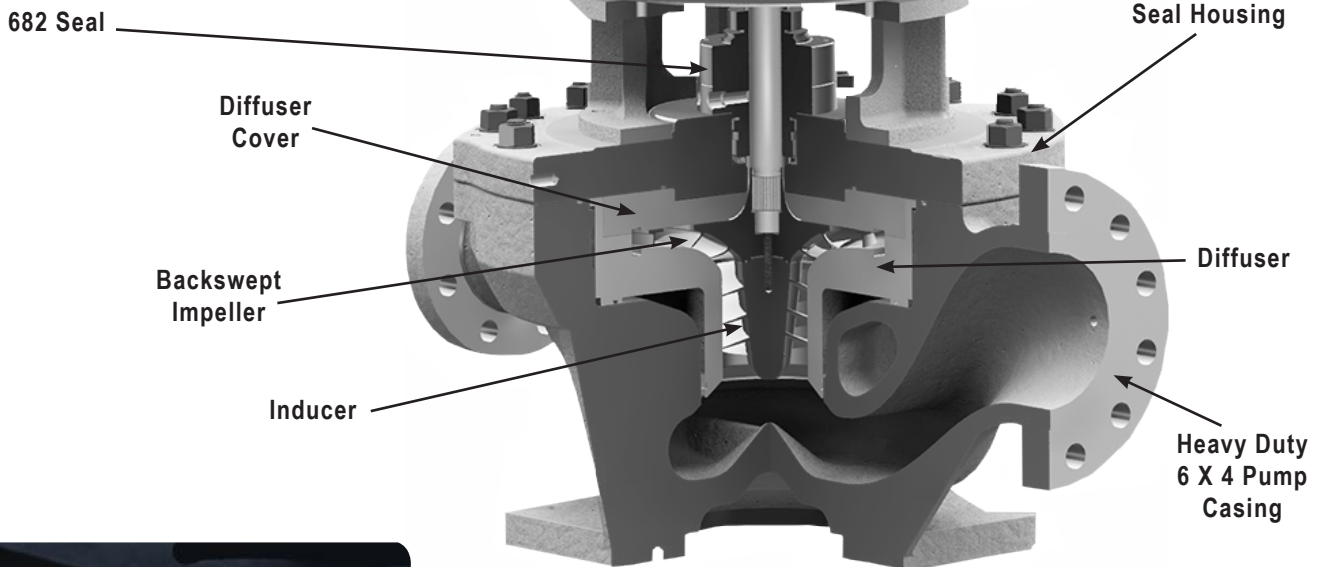

◀ Sundyne innovation delivers broad(er) inducer technology for low NPSHr associated with the gas plant and NGL services.

**Ultra-Low NPSHr Pump:**

Sundyne engineers have decades of impeller and inducer design experience. They leveraged that experience and analysis to develop a heavy duty vertical inline centrifugal pump with NPSHr performance that is unparalleled in oil and gas production, midstream and hydrocarbon processing industries. The LMV-803Lr is capable of running ultra-low NPSHr <5 ft (1.5m) up and down the curve without losing performance.

- ◆ Flows to 800 gpm (180 m<sup>3</sup>/hr)
- ◆ Heads to 1,000 ft (305m)

**Rugged 6x4 Casing:**

The LMV-803Lr is the most robust direct drive pump from Sundyne to date. A rugged 6x4 casing allows for higher pressures and higher flows.



# SUNDYNE DIRECT DRIVE PUMPS

Setting the industry standard in vertical pump design.

**Testing Available:**

- ✓ Performance Test
- ✓ Pump Case Hydrostatic Test
- ✓ NPSH Suppression Test
- ✓ Radiography Inspection
- ✓ Liquid Penetrant Inspection
- ✓ Mill Test or Material Certs
- ✓ Magnetic Particle Inspection
- ✓ Hardness Testing

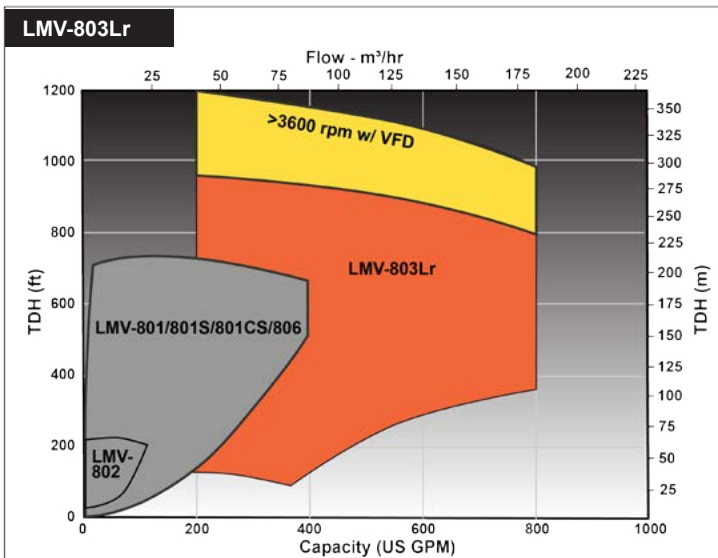

**Direct Drive Pump Applications:**

Sundyne vertical inline, direct drive, overhung impeller, single stage centrifugal pumps are specifically designed to save valuable space in refineries, midstream gas processing facilities, petrochemical and chemical plants. They are designed to be used as:

- ◆ Feed pumps ◆ Booster pumps ◆ Bottoms pumps
- ◆ Wash water pumps ◆ Reflux pumps ◆ Condensate pumps

**Installed Cost Benefit:**

Available as either an API-610 OH3 or API OH5 type pump, the LMV-803Lr can be installed at grade level, eliminating the need and expense of pump installation in a pit or construction of a tall distillation tower to provide ample head.



The Sundyne LMV-806 API 610, is a direct drive vertical inline, single stage, overhung impeller centrifugal pump in a standard OH5 configuration. OH3 when used with the bearing frame option. This model delivers:

Flows to 380 gpm (86 m<sup>3</sup>/hr)    Heads to 760 ft (232 m)    This heavy duty API 610 pump is ideal for Hydrocarbon processing, including Refining and Petrochemical, Chemical processing and midstream natural gas.

# LMV-806

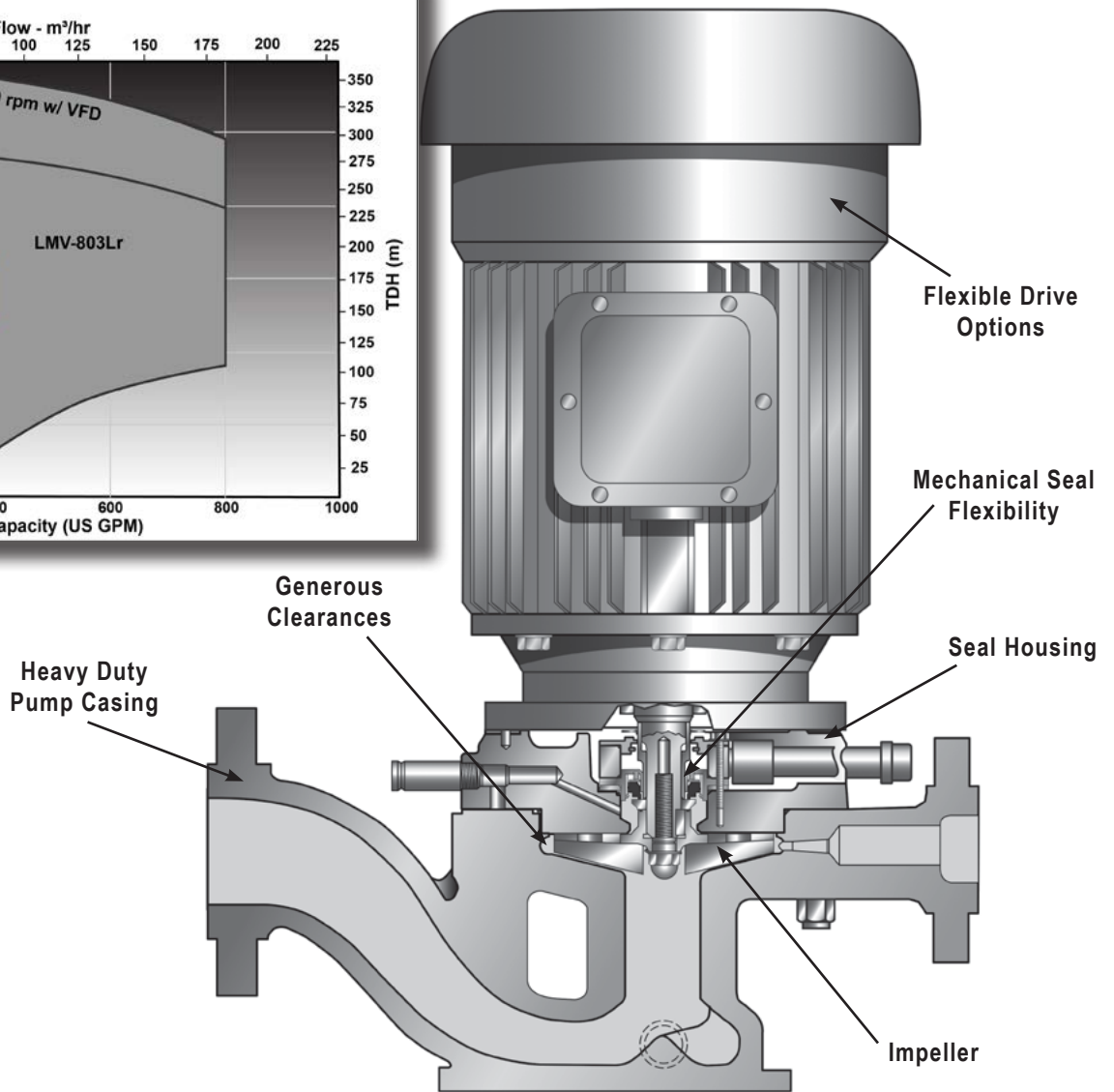
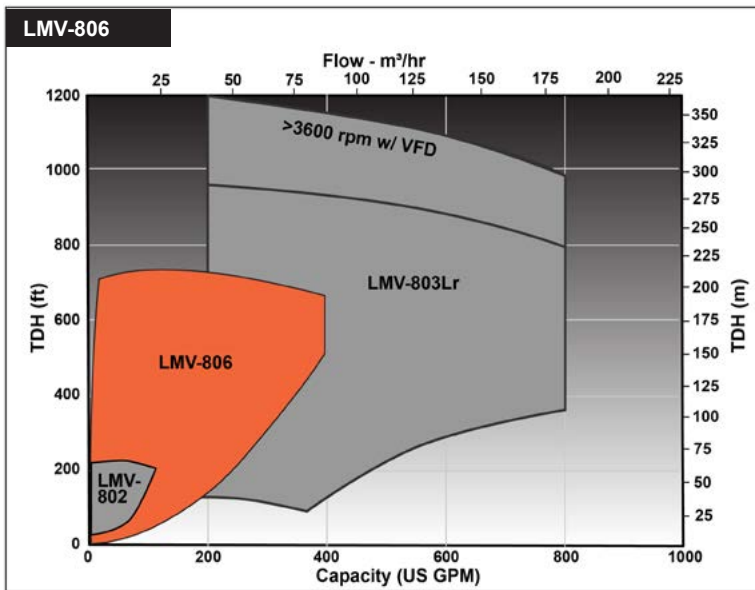

# Sales & Service Support



To learn more about Sundyne Genuine Parts and Service, visit [www.sundyne.com](http://www.sundyne.com) or contact the representative nearest you.

## Backed By Global Support

Sundyne has an extensive global network of local certified Authorized Service Centers (ASC's) to provide service and support to you. Utilize your local Sundyne Authorized Service Center to provide:

### Routine Maintenance:



Clean, inspect and replace standard wear components on your Sundyne branded pumps and compressors including bearings, gaskets, o-rings and lubricants. Generally, your products will be turned around in less than one week.

### Sundyne Genuine Parts:



Replacement parts and components are stocked on-site reducing your need for on-site spares inventory. Custom parts can be ordered and expedited quickly to keep you up and running.

### Onsite Service and Repair:



Local technical expertise with the right training, diagnostic equipment and parts to keep your processes running smoothly.

### Root Cause Corrective Action (RRCA):



Reduce repair costs and extend equipment life by quickly diagnosing root cause problems and proving solutions to prevent future failures.

**COMPARE  
AND**

# Specify The Sundyne

**OH3 or OH5**



**801**



**801S**



**801CS**

Upgrade  
To An API 682  
Cartridge Seal  
Today!

**Key Benefit:**

**Easy To Convert**

**Sealless Magnetic Drive**

**Cartridge Seal**

Heads To	10 to 720 ft (3 to 219 m)	0 to 720 ft (0 to 220 m)	0 to 720 ft (0 to 219 m)
Flows To	10 to 380 gpm (2.3 to 86 m <sup>3</sup> /hr)	20 to 380 gpm (4.5 to 86 m <sup>3</sup> /hr)	10 to 380 gpm (2 to 86 m <sup>3</sup> /hr)
Max Power	100 hp (75 KW)	100 hp (75 KW)	75 hp (55 KW)
Temp Range	-200 to 650°F (-130 to 340°C)	-40 to 400°F (-40 to 205°C)	-40 to 300°F (-40 to 149°C)
Number of Stages	1.0	1.0	1.0
Max Case Working Pressure	2,160 psig (152 kg/cm <sup>2</sup> )	580 psig (40 bar)	2,160 psig (152 kg/cm <sup>2</sup> )
Max Suction Pressure	1,000 psig (71 kg/cm <sup>2</sup> )	--	875 psi (60 bar)
Speed Range	1,450 to 3,550 rpm	1,450 to 3,550 rpm	1,450 to 3,550 rpm
Bearing Materials Available	Ball Bearings (bearing frame)	Silicone Carbide	Silicone Carbide
Max Viscosity	750 cp	200 cp	750 cp
Industry Standard	API 610 (OH3, OH5)	API 685	API 610 (OH3)
Solids Range	0.015" (0.381mm), 400 microns	Clean Liquids Only	0.015" (0.381mm), 400 microns
Mounting Configurations	Vertical	Vertical	Vertical
Seal Configurations Available	Single, Double, Tandem	Sealless	Single, Double, Tandem, Cartridge
Available Inducer	Yes	Yes	Yes
Available Flanges	600#, 900#, 1500, RF, RTJ	600#, RF	600#, RF, 900# RF Optional
Pump Case Corrosion Allowance	0.125" (0.17 mm)	0.125" (0.175 mm)	0.125" (3.17 mm)
Suction and Discharge Size	3" x 2"	3" x 2"	3" x 2"
API Plans for Sundyne Pumps	11, 12, 13, 21, 23, 31, 32, 41, 52, 53, 54, 61, 62	--	11, 12, 13, 21, 23, 31, 41, 52, 53, 54, 61, 62, J



# That Delivers Your BEP

**Best  
Efficiency  
Point**



**802**

Low Flow

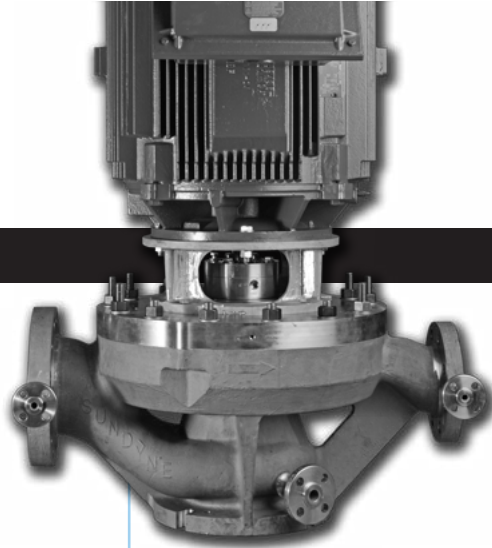

**803Lr**

High Flow, Low NPSHr



**806**

Low First Cost

20 to 210 ft (4 to 45 m)

10 to 150 gpm (8 to 27 m<sup>3</sup>/hr)

50 hp (37 KW)

-200 to 650°F (-130 to 340°C)

1.0

1,440 psig (101 kg/cm<sup>2</sup>)

600 psig (42 kg/cm<sup>2</sup>)

1,450 to 3,550 rpm

Ball Bearings (bearing frame)

750 cp

API 610 (OH3, OH5)

0.015" (0.381mm), 400 microns

Vertical

Single, Double, Tandem

Yes

600#, RF

0.125" (3.17 mm) 7 mm

3" x 2"

11, 12, 13, 21, 23, 31, 32, 41, 52,

53, 54, 61, 62

120 to 1,000 ft (37 to 305 m)

200 to 800 gpm (45 to 181 m<sup>3</sup>/hr)

400 hp (298 KW)

0 to 300°F (-18 to 149°C)

1.0

1,000 psig (70 kg/cm<sup>2</sup>)

--

1,450 to 3,550 rpm

Ball Bearings (bearing frame)

750 cp

API 610 (OH3, OH5)

0.015" (0.381mm), 400 microns

Vertical

Single, Double, Tandem, Cartridge

Yes

600#

0.125" (3.17 mm)

6" x 4"

11, 12, 14, 52, 53, 61, 62

10 to 760 ft (3 to 231 m)

10 to 380 gpm (2.5 to 86 m<sup>3</sup>/hr)

75 hp (55 KW)

-40 to 350°F (-40 to 175°C)

1.0

710 psig (50 kg/cm<sup>2</sup>)

--

1,450 to 3,550 rpm

Ball Bearings (bearing frame)

750 cp

API 610 (OH3, OH5)

0.015" (0.381mm), 400 microns

Vertical

Single, Double, Tandem

Yes

300#, 600#, RF

0.125" (3.17 mm)

3" x 2"

11, 12, 13, 21, 23, 31, 32, 41, 52,

53, 54, 61, 62,



**COMPRESSORS**

**PUMPS**

**GENUINE PARTS**

**SERVICE**

**Sundyne, LLC**  
14845 West 64th Avenue  
Arvada, Colorado 80007  
USA  
1-866-Sundyne  
Phone: 1 303 425 0800  
Fax: 1 303 425 0896  
[www.sundyne.com](http://www.sundyne.com)

**United Kingdom**  
Marshall Road  
Hampden Park Industrial Estate  
Eastbourne East Sussex, BN22 9AN  
United Kingdom  
Phone: +44 1323 452000  
Fax: +44 1323 503369

**France**  
13-15, Bld. Eiffel - B.P. 30  
21604 Longvic Cedex  
France  
Phone: +33 (0)3 80 38 33 00  
Fax: +33 (0)3 80 38 33 66

**Spain**  
**Ctra. Madrid-Toledo, Km.30.8**  
45200 Illescas  
Toledo, Spain  
Phone: +34 925 53 45 00  
Fax: +34 925 51 16 00

**China**  
Building 1, No. 879 Shen Fu Road  
XinZhuang Industrial Zone  
Min Hang District  
Shanghai, China 201108  
Phone: +86 21 50555005  
Fax: +86 21 54425265

To learn more about Sundyne,  
visit [www.sundyne.com](http://www.sundyne.com) or contact  
the representative nearest you.

**RELIABILITY  
REALIZED.™**

All information provided is  
subject to change without notice.

© 2018 Sundyne, LLC  
All Rights Reserved. Other logos  
and trade names are property of  
their respective owners.

Sundyne Direct Drive Brochure\_020718:  
A4 (v.2) POD