

VSMK, VSMKD, VND  
Vertical Sump Pumps

**VS4 Type**

*API-610, 10th edition full compliant  
ISO 13709*

MARELLI

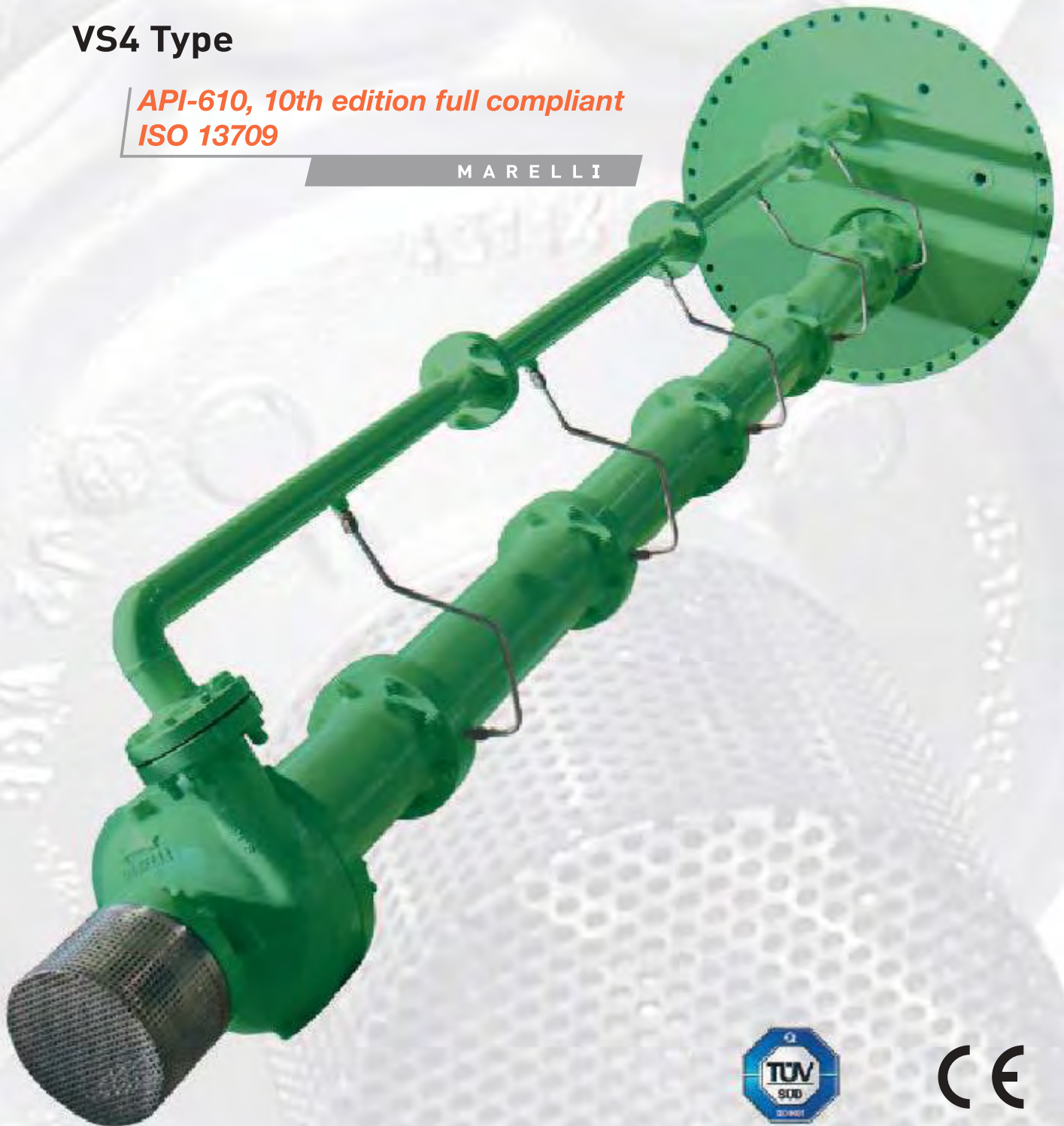

## Sundyne Marelli

More than 45 years of experience in centrifugal pump design, development, manufacturing and service, to fulfill the latest standards for petroleum, petrochemical process and heavy duty processing industries, as full compliance machinery.

### Applications

Sundyne Marelli, develops tailor made solutions for the medium-pressure movement of water, hydrocarbon, CO<sub>2</sub> and other process liquids. Our solutions meet the most stringent customer specifications for the following heavy industries:

- ▶ Refineries
- ▶ Desalination plants
- ▶ Process charge
- ▶ API basins
- ▶ Condensate extraction
- ▶ Tank Farms
- ▶ Tanks fluid transfer
- ▶ Petrochemical plants
- ▶ Fertilizers
- ▶ Oil fields and terminals
- ▶ Off-shore and on-shore installations for petroleum and gas
- ▶ Reverse osmosis
- ▶ Synfuels
- ▶ Paper mills
- ▶ Pharmaceutical industry
- ▶ Other intensive high-pressure services and systems, that demand high reliability and efficient equipment

### Design

Sundyne Marelli VS4 type sump pump series are vertical process pumps, single volute, radial split, self-venting, vertical split casing and single stage. End suction, top discharge. Hydraulically balanced impeller, easy to remove without disconnecting the piping. Shaft completely covered with shaft-sleeve. Oil lubricated bearing support. Semi-open impeller construction is also available.

### Operating Data

- ▶ Capacities: to 3180 usgpm (800m<sup>3</sup>/hr)
- ▶ Heads: to 656 feet (200 m)
- ▶ Temperature Range: to 450 °F (232 °C)
- ▶ Pit Depths: to 30 feet (10 m)

### Materials

PART	According to Table H1 - API-610 10th Edition						
	S1	S5	S6	S8	C6	A8	D1
<b>Pressure Casing</b>	Carbon Steel (A216 WCB)				12% CHR	316 AUS	Duplex
<b>Impeller</b>	Cast Iron	Carbon Steel	12% CHR	316 AUS	12% CHR	316 AUS	Duplex
<b>Wear Rings</b>	Cast Iron	12% CHR Hardened		Hard-faced 316 AUS	12% CHR Hardened	Hard-faced 316 AUS	Hard-faced Duplex
<b>Shaft</b>	Carbon Steel	AISI 4140		316 AUS	12% CHR	316 AUS	Duplex
<b>Bearing Housing</b>	Carbon Steel (A216 WCB)						
<b>Case Gasket</b>	AUS, Spiral Wound			316 AUS Spiral Wound	AUS, Spiral Wound	316 AUS Spiral Wound	Duplex SS Spiral Wound
<b>Column Discharge Pipe</b>	Carbon Steel					316 AUS	Duplex

OTHER MATERIALS AND METALURGIES AVAILABLE UPON REQUEST

## Optional Features

Sundyne Marelli provides sump pump series with a range of customized features, to meet specific application requirements.

**Lubrication** with constant level oiler.

Optional lubrication with pure or purge oil mist - Optional lubrication with grease

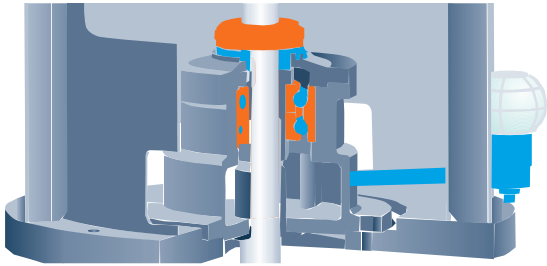

**Bearing housing** with double row bearings with machined brass or iron cages.

**Labyrinth seal** to avoid external contamination.  
Optional Inpro/Seal labyrinth seals

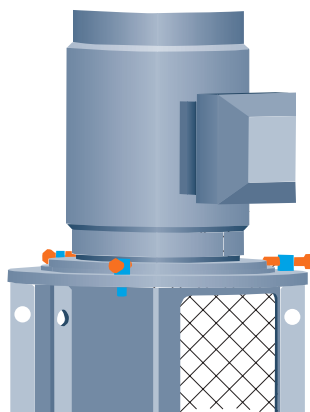
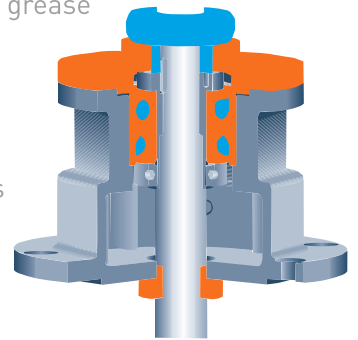

Transverse alignment positioning **jackscrews** for electric motor

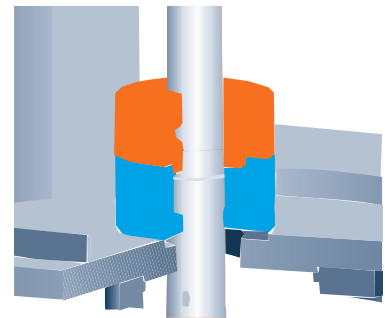

**Seal chamber.** Designed to API-610 / ISO 13709.  
Ready to fit cartridge seals under  
API-682 3<sup>rd</sup> Ed / ISO 21049  
Optional sealing with soft packing and retainer

**Split keyed shaft**  
arrangement for as per API  
610 10<sup>th</sup> Edition.  
Option. **Jacketed enclosing**  
pipe for the shaft when  
pumping abrasive fluids

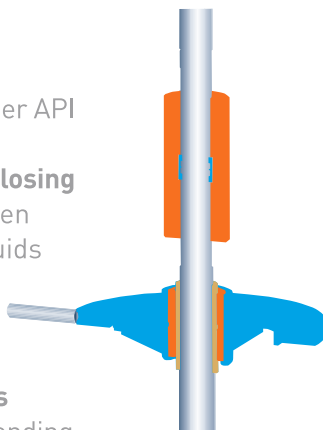

**Gaskets or O-rings**  
a requested or depending  
on the service conditions

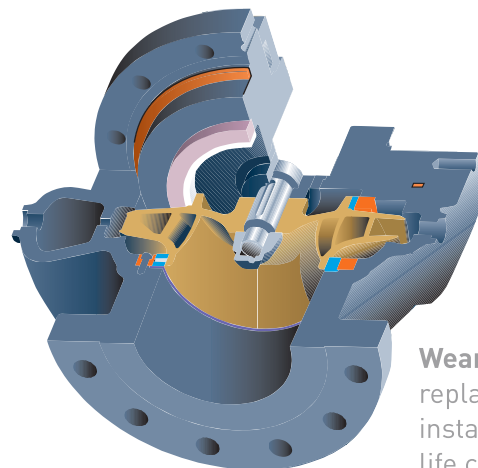

**Wearing rings.** Field  
replaceable, easy  
installation for better  
life cycle cost (LCC)

## **Sundyne Marelli V54 Series**

**Precision engineered pumps meeting rigorous customer requirements wide range of applications, while reducing the total life cycle cost (LCC) and improving reliability (MTBF & MTBR).**

**API-610, 10th edition full compliant  
ISO 13709 VS4 Type**

**Standard Features and Benefits**

- API-610 10th Edition / ISO 13709 Full Compliance for reliability and accountability.
- All pumps within VS4 series are suitable for operation at 50 Hz and 60 Hz.
- Higher efficiencies. Due to a design with tangential discharge and wide variety of hydraulics to match all types of duty points.
- Labyrinth bearing seals to avoid external contamination and maximize seal and lubrication life.
- Highly maintainable and replaceable wear rings to reduce overall life cycle costs (LCC).
- Mechanical seal chamber API-682 3rd Edition. Also complies to API-610 standards.
- Choice of multiple impellers in each hydraulic pump casing for optimum efficiency over a wide operating range.
- A variety of instrumentation options are available for monitoring all key operating parameters (temperature, pressure, vibrations, etc.).

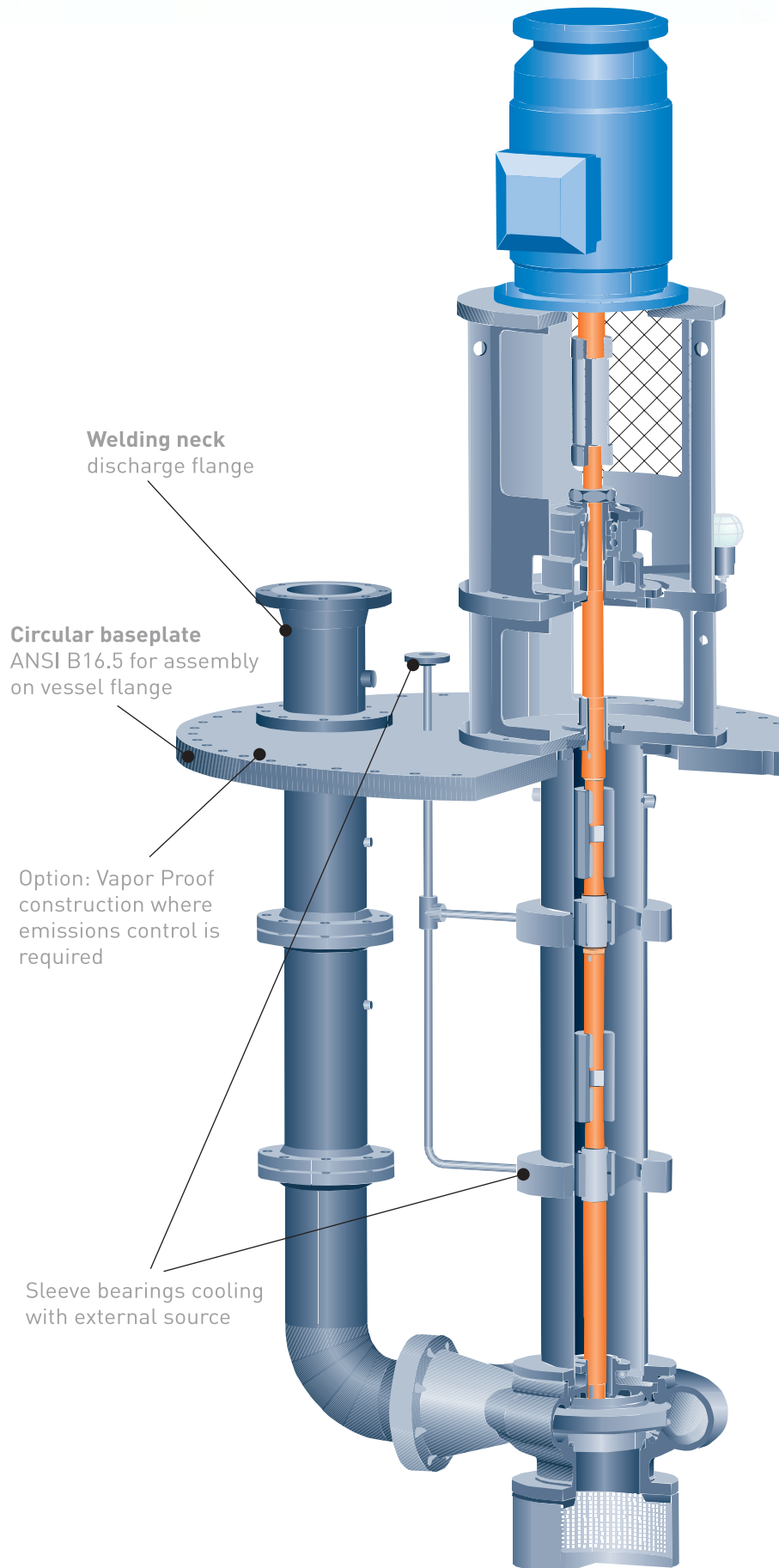

Welding neck  
discharge flange

Circular baseplate  
ANSI B16.5 for assembly  
on vessel flange

Option: Vapor Proof  
construction where  
emissions control is  
required

Sleeve bearings cooling  
with external source



**Motor support.** Strong construction that supports the pump column, bearing housing and electric motor

**Spacer Coupling** to facilitate dismantling of mechanical seals

**Non sparking coupling guard**

**Discharge flange** according to ANS B16.5 300#RF, 600#RF and 900#RF and their required serrations. ASME/DIN flanges are also available. Top or Side orientation. Socket Weld flanges

**Regulating nut** for vertical adjustment of the rotor

**Discharge piping** bolted to the baseplate for easy disassembling. Option Vapour Proof Construction: Discharge piping welded to the baseplate depending on the service

**Bearing housing** with double row bearings with machined brass or iron cages.

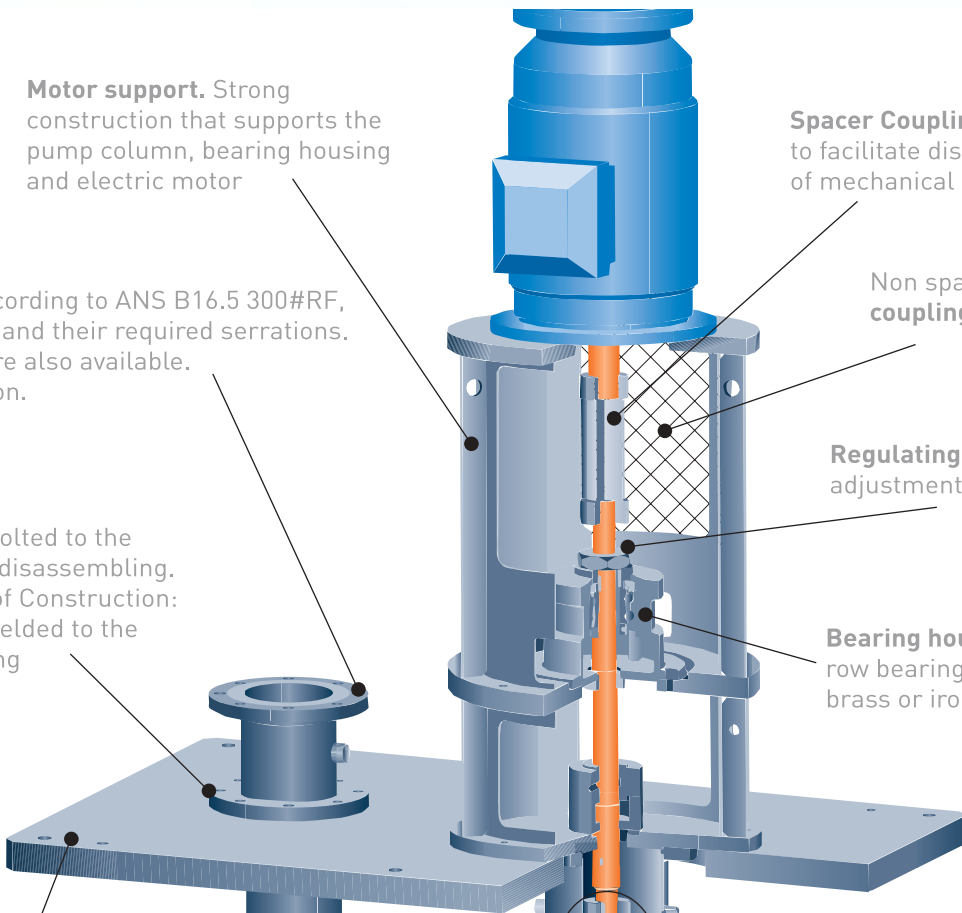

**Split shaft** arrangement for as per API 610 10<sup>th</sup> Edition. Option. Enclosing pipe for shaft when pumping abrasive fluids

**Rectangular baseplate** for grouting  
Option: Integral lifting lugs in baseplate

**Maximum space** between shaft bushings in order to maintain the first critical speed above the maximum allowable continuous speed as per API 610 10<sup>th</sup> Ed.

Sleeve bearings **cooling** with process fluid

**Bearing Bushes** in Graphite+Teflon or AISI 316 + Teflon or Bronze depending on the service or temperature

**Pipeline** for cooling would be made with tubing or piping as request

**Suction strainer.** It screens oversize particles to avoid damage and/or erosion of pump casing and impeller

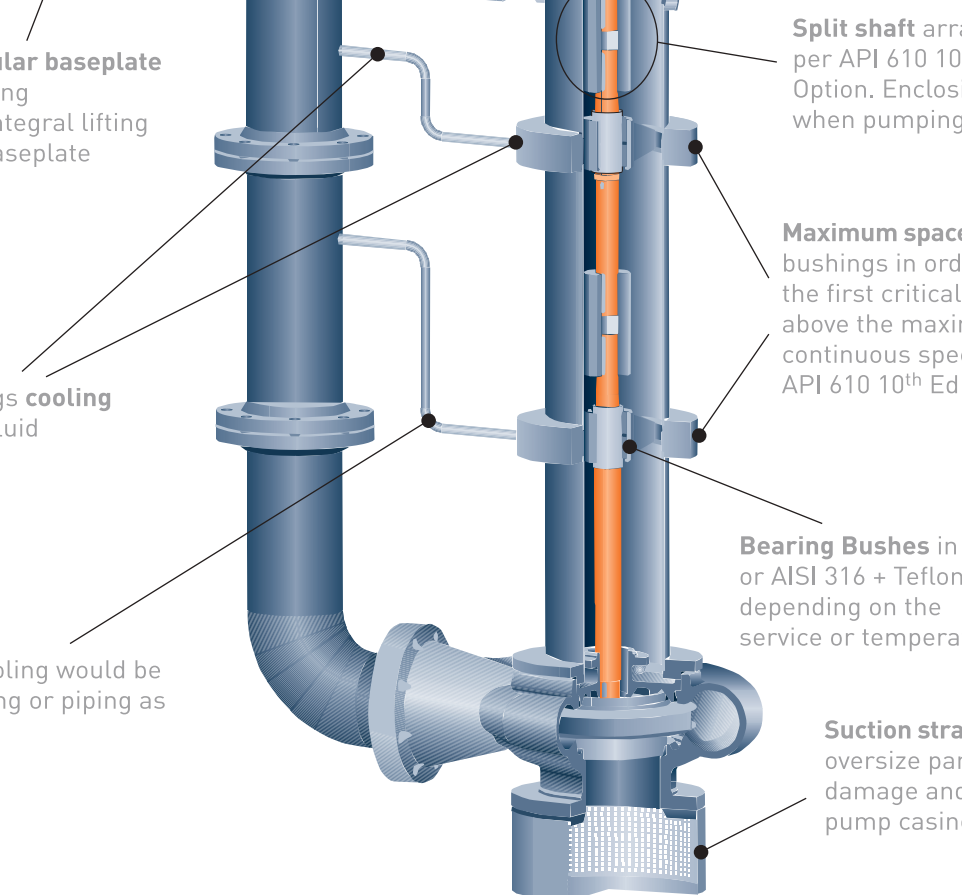



NOTES:

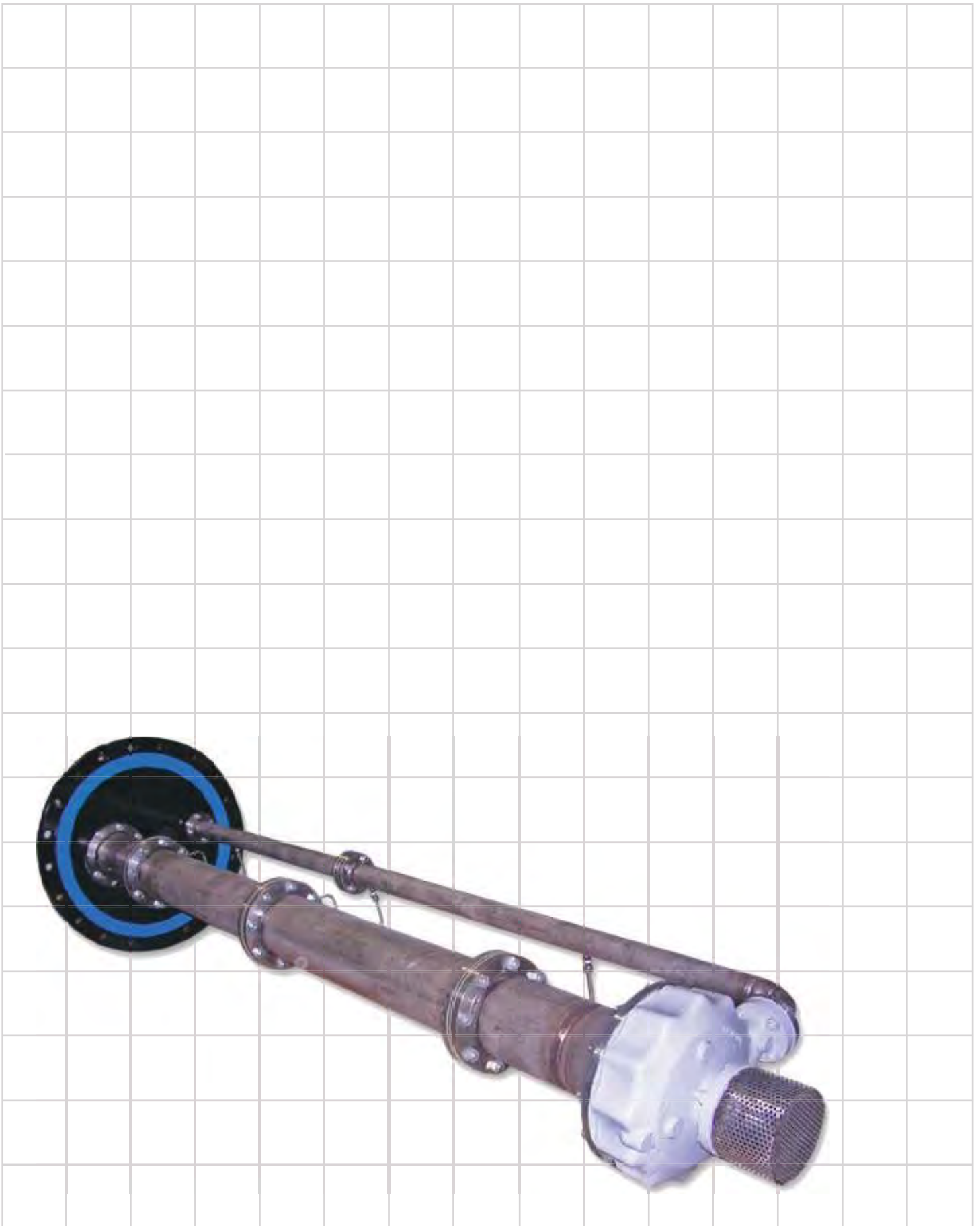





Sundyne Headquarters:

**Sundyne, LLC**  
 14845 West 64th Avenue  
 Arvada, Colorado 80007  
 USA  
 1-866-Sundyne  
 Phone: 1 303 425 0800  
 Fax: 1 303 940 2911  
 www.sundyne.com

**Sundyne China:**  
 Building 1, No. 879 Shen Fu Road  
 XinZhuang Industrial Zone  
 Min Hang District  
 Shanghai, China 201108  
 Ph: +86 21 5055 5005  
 Fax: +86 21 5442 5265

Sundyne France:  
**Sundyne International S.A.**  
 13-15, Bld. Eiffel - B.P. 30  
 21604 Longvic Cedex  
 France  
 Phone: +33 (0)3 80 38 33 00  
 Fax: +33 (0)3 80 38 33 66

Sundyne Spain:  
**Sundyne Marelli Bombas, S.R.L.**  
 Ctra. Madrid-Toledo, Km.30.8  
 45200 Illescas  
 Toledo, Spain  
 Phone: +34 925 53 45 00  
 Fax: +34 925 51 16 00

Sundyne United Kingdom  
**Sundyne HMDKontro Sealless Pumps, Ltd.**  
 Marshall Road  
 Hampden Park Industrial Estate  
 Eastbourne East Sussex, BN22 9AN  
 United Kingdom  
 Phone: +44 1323 452000  
 Fax: +44 1323 503369

**Worldwide Sales Headquarters**  
 Unit 2 Harvington Business Park  
 Hampden Park Industrial Estate  
 Brampton Road  
 Eastbourne East Sussex, BN22 9BN  
 United Kingdom  
 Phone: +44(0) 1323 452125

All information provided is subject to change without notice.

© 2013 Sundyne, LLC  
 All Rights Reserved. Other logos and trade names are property of their respective owners.

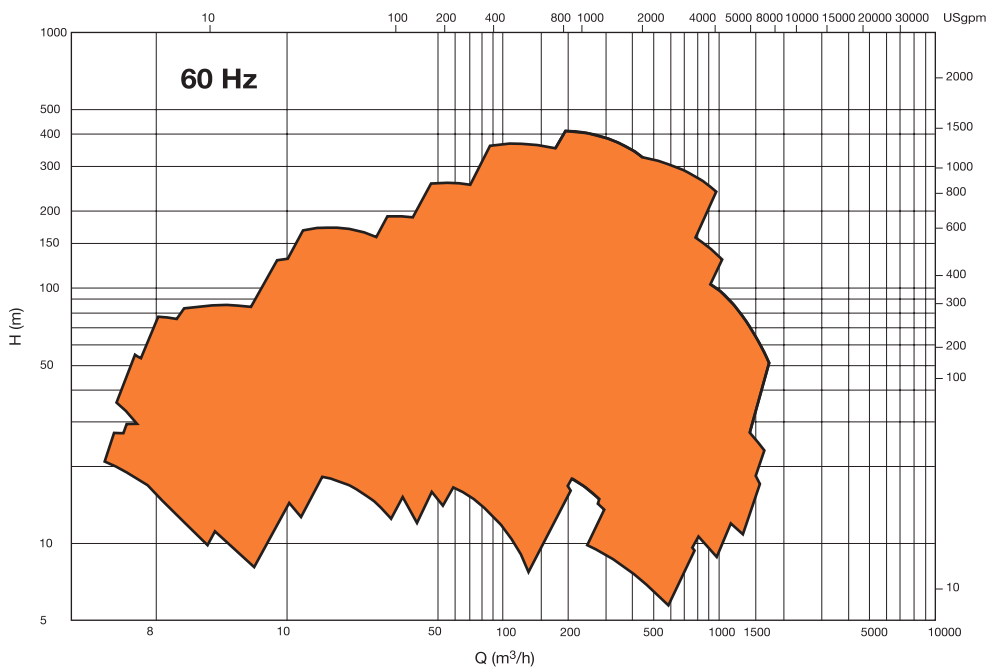
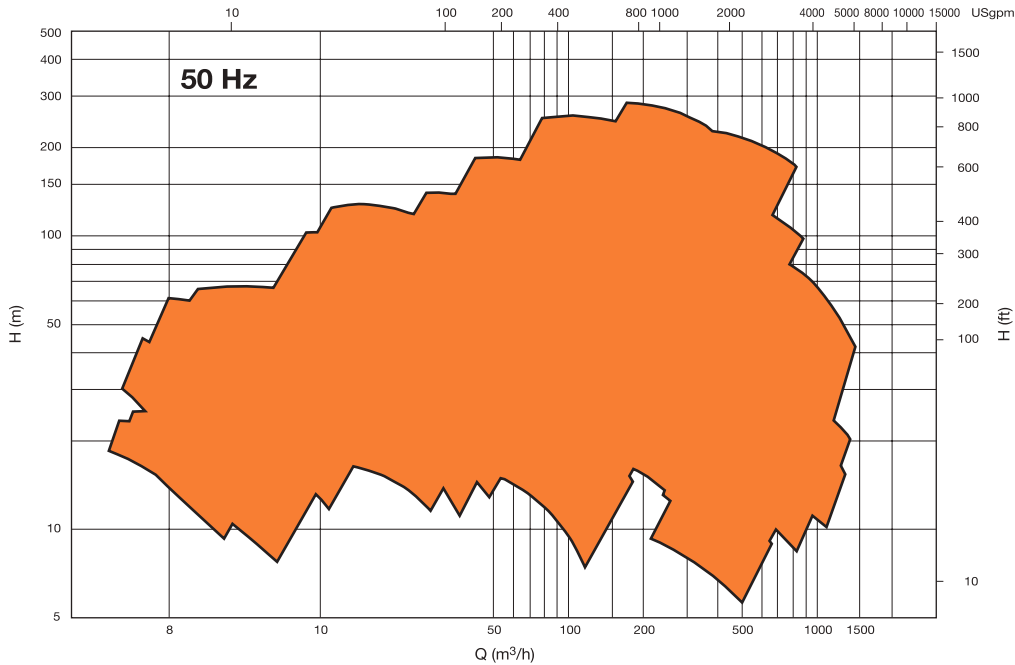

To locate the global representative, distributor or authorized service center nearest you, or for additional information please visit [www.sundyne.com](http://www.sundyne.com)

**GLOBAL STRENGTH**, powered by people.