

**SMK**  
Overhung, End-suction,  
Horizontal Single & Double Volute  
Radially Split, Pump

**OH2 Type** *API-610, 10th edition*  
*ISO 13709*

MARELLI



## Sundyne Marelli

More than 40 years of experience in centrifugal pump design, development, manufacturing and service, to fulfill the latest standards for petroleum, petrochemical process and heavy duty processing industries, as full compliance machinery.

### Applications

Sundyne Marelli, develops tailor made solutions for the movement of water, hydrocarbon, CO2 and other process liquids. Our solutions meet the most stringent customer specifications for the following heavy industries:

- ▶ Refineries
- ▶ Petrochemical plants
- ▶ Crude oil and gas pipelines
- ▶ Off-shore and on-shore installations for petroleum and gas
- ▶ Reverse osmosis
- ▶ Synfuels
- ▶ Heavy-duty industry applications
- ▶ Other intensive services and systems, that demand high reliability and efficient equipment

### Design

Sundyne Marelli SMK pump series are end-suction, centerline mounted, radial split, overhung horizontal single and double volute centrifugal pumps. SMK OH2 type pumps fully complies to API-610 10th edition / ISO 13709 standards.

### Operating Data

- ▶ Capacities: up to 1600m<sup>3</sup>/hr (7000 usgpm)
- ▶ Heads: up to 360 meters (1200 feet)
- ▶ Max Working Pressure: up to 50 bar (725 psi)
- ▶ Temperature Range: -150 °C (-238 °F) to 450 °C (842 °F)
- ▶ Rotational speed: up to 4000 rpm

### Materials

PART	According to Table H1 - API-610 10th Edition						
	S1	S5	S6	S8	C6	A8	D1
<b>Pressure Casing</b>	Carbon Steel (A216 WCB)				12% CHR	316 AUS	Duplex
<b>Impeller</b>	Cast Iron	Carbon Steel	12% CHR	316 AUS	12% CHR	316 AUS	Duplex
<b>Wear Rings</b>	Cast Iron	12% CHR Hardened		Hard-faced 316 AUS	12% CHR Hardened	Hard-faced 316 AUS	Hard-faced Duplex
<b>Shaft</b>	Carbon Steel	AISI 4140		316 AUS	12% CHR	316 AUS	Duplex
<b>Bearing Housing</b>	Carbon Steel (A216 WCB)						
<b>Case Gasket</b>	AUS, Spiral Wound			316 AUS Spiral Wound	AUS, Spiral Wound	316 AUS Spiral Wound	Duplex SS Spiral Wound

OTHER MATERIALS AND METALURGIES AVAILABLE UPON REQUEST

## Optional Features

Sundyne Marelli provides the SMK pump series with a range of customized features, to meet specific application requirements.

### For High Temperature

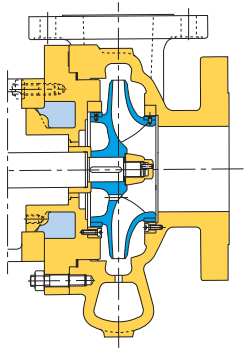

- Cooled mechanical seal chamber.

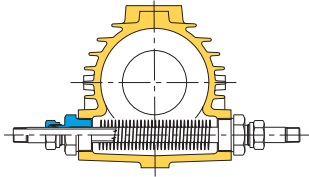

- External cooling for bearing housing with finned heat exchanger fed with inert fluid and/or water.

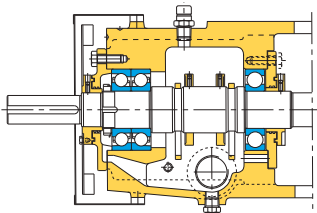

- Convection venting for bearing housing with a low noise fan placed at rear in coupling side.

### For High Suction Pressure

- Heavy duty bearing housings designed for high suction pressure applications.
- Mechanical seals to meet safety and environmental requirements.
- Pump casing and seal chamber designed for high suction pressure.
- Engineered bearing solutions available.

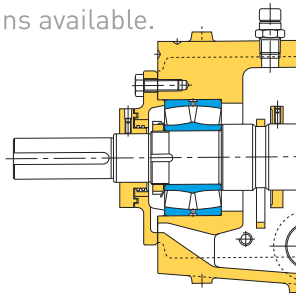

### For Lubrication System

- Purge ports with drain valve. Test gauges for condition analysis.
- Oil mist lubrication system, with purge ports, is outboard for assuring mist flow through each bearing.

### For Coking Services

- Backwash system for wear rings and neck bushing.
- Specific coke crusher available upon request.

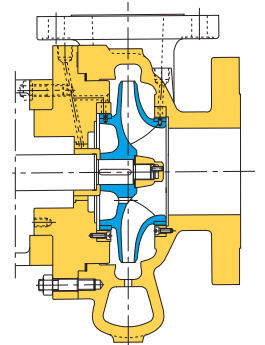

### Baseplate Designs

- Pre-grouted and non-grouted for all driver types.
- Special base designs to match oversize drivers, pumps and turbines.
- Tailor made baseplates are available.
- Skid mounting and oil field designs available.

### Other Available Solutions

- State of the art inducer designs to improve suction capacity.
- Top suction designs on demand.
- Lateral right/left side pump discharges for matching existing pipe work at plant.

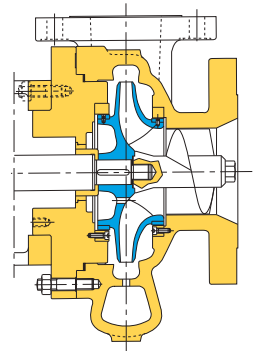

## **Sundyne Marelli SMK Series**

**Precision engineered pumps meeting rigorous customer requirements in a multitude of applications, while reducing the total life cycle cost (LCC) and improving MTBM.**

## API-610, 10th Edition ISO 13709 OH2 Type

### Standard Features and Benefits

- API-610 10th Edition / ISO 13709 Full Compliance for reliability and accountability.
- All pumps within SMK series are suitable for operation at 50 Hz and 60 Hz.
- Higher efficiencies. Due to a design with tangential discharge and wide variety of hydraulics to match all types of duty points.
- Centerline mounted pump casing maintains alignment during operation at elevated temperatures.
- Low suction specific speed low NPSH characteristics, with a wide choice of impellers for optimum efficiency over a large operating range.
- Finned bearing housing to provide maximum heat dissipation under API-610 compliance.
- Isolation chamber at bearing housing. Thermal barrier amongst mechanical seal chamber and bearing housing.
- Deflection system with fins to improve cooling.
- Labyrinth bearing seals to avoid external contamination and maximize seal and lubrication life.
- Highly maintainable and replaceable wear rings to reduce overall life cycle costs (LCC).
- Mechanical seal chamber API-682 3rd Edition. Also complies to API-610 standards.
- Socket welded flanged drains and vents as standard. Gussets and bracing also available.
- Choice of multiple impellers in each hydraulic pump casing for optimum efficiency over a wide operating range.
- A variety of instrumentation options are available for monitoring all key operating parameters (temperature, pressure, vibrations, etc.).

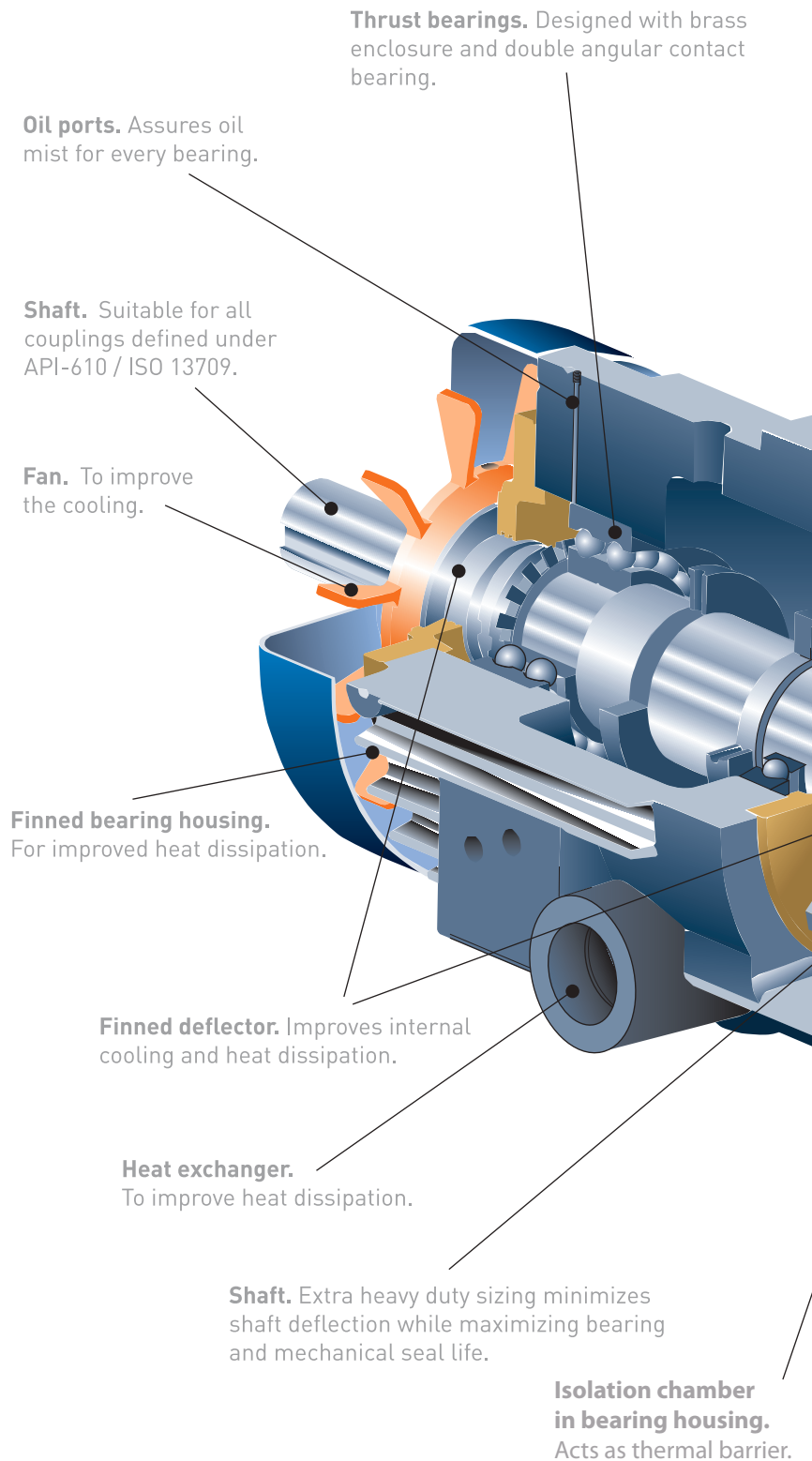

**Bearing Housing.** Multiple sizes available to meet load requirements.

**Seal chamber.** API-610 heating or cooling available.

**Casing gasket.** Confined compression gasket with metal to metal rabbet fit.

**Pump casing.** Dual volute configuration to minimize radial loads and shaft deflection (over 3" discharge nozzle size). Flanges designed to ASME VIII. Top suction and lateral discharges available.

**Flanges.** ANSI B16.5 300#RF, 600#RF & 900#RF and their required serrations. ASME/DIN/ISO/JIS flanges also available.

**Casing centerline** to meet API-610 / ISO 13709 nozzle loads.

**Impellers.** Multiple designs for every pump casing. Dynamically balanced. Low suction specific speed and NPSH characteristics.

**Seal chamber.** Designed to API-610 / ISO 13709. Ready to fit cartridge seals under API-682 / ISO 21049.

**Wear rings.** Field replaceable, easy installation for better life cycle cost (LCC).

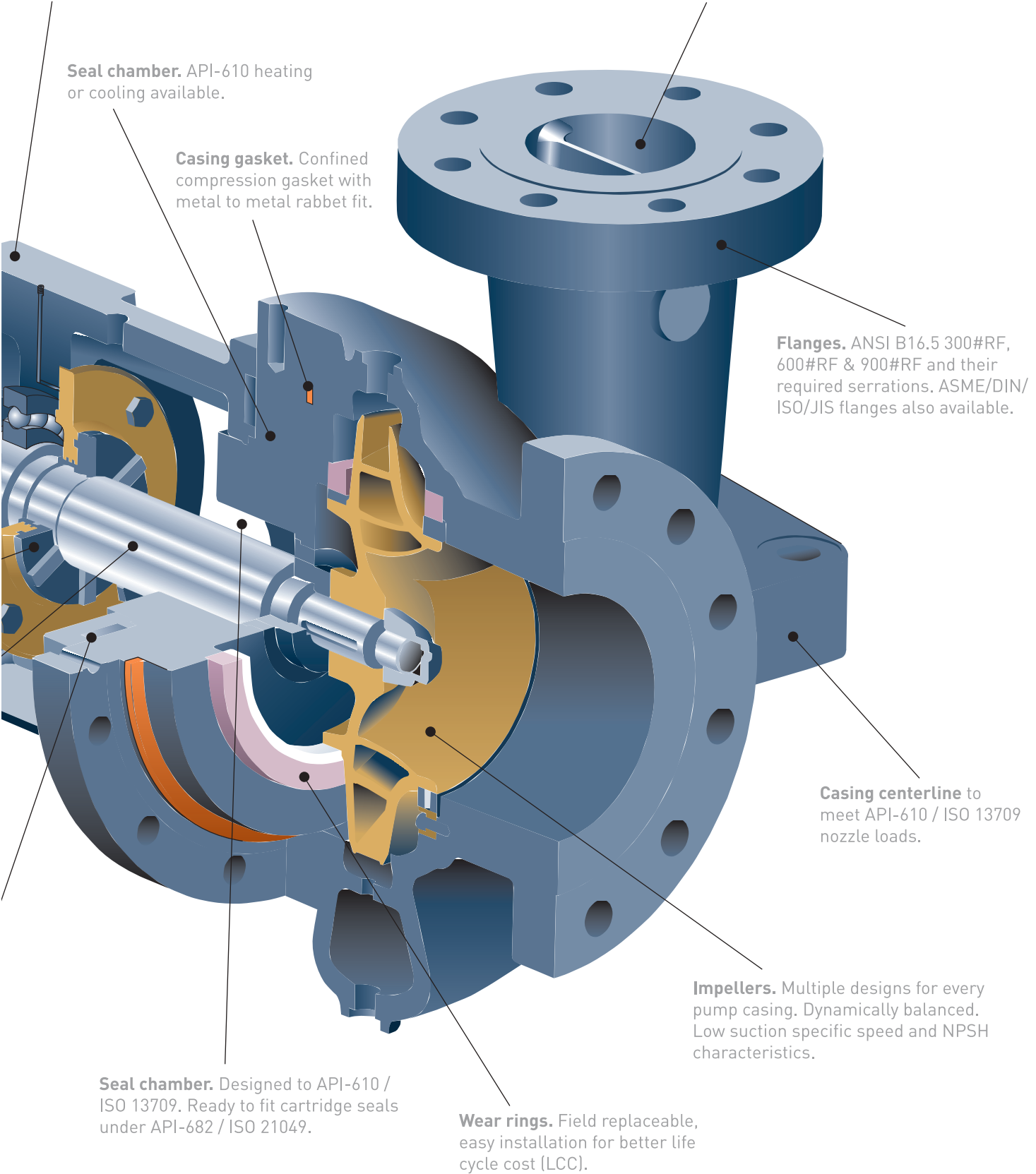

NOTES:

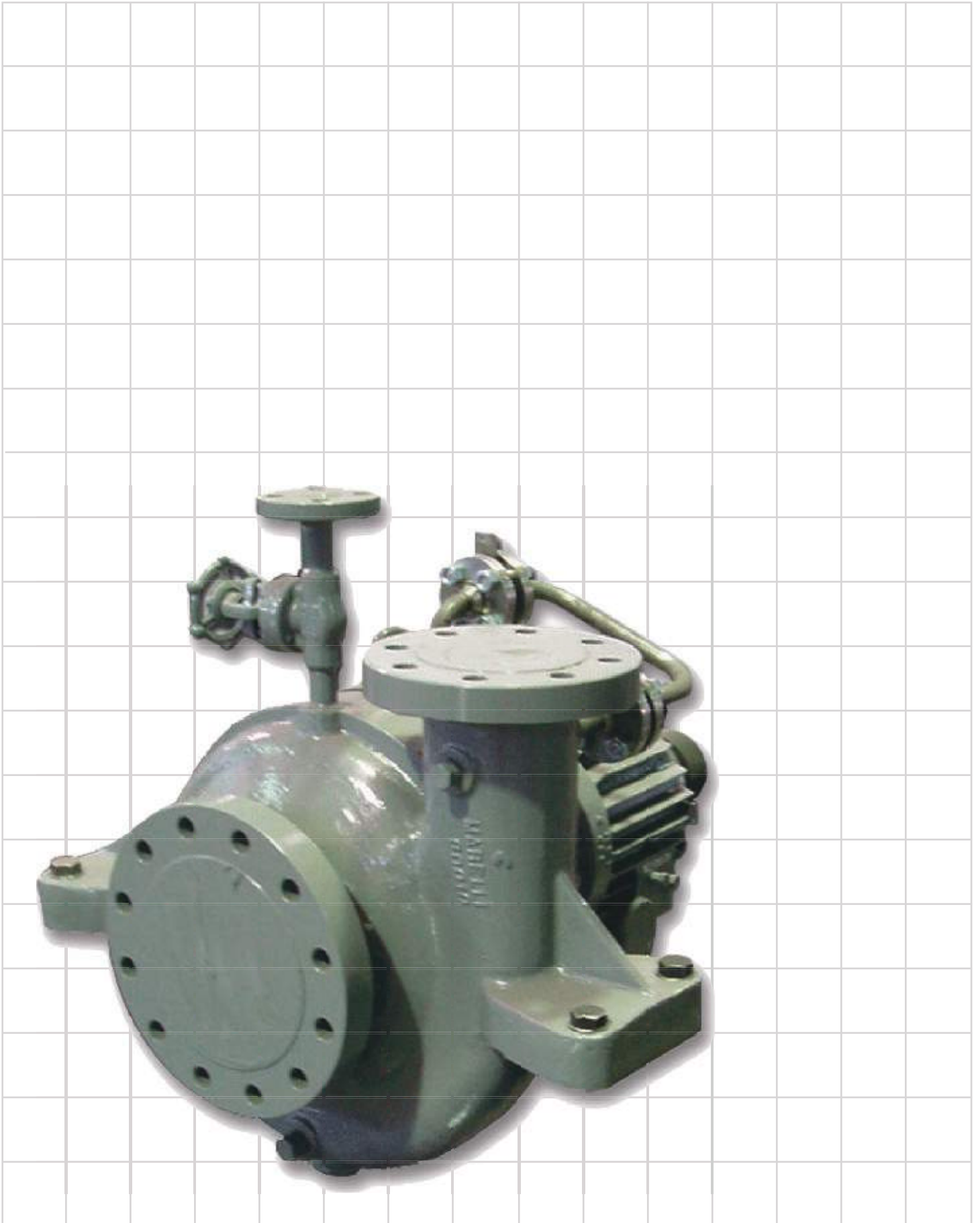



## Performance Curves

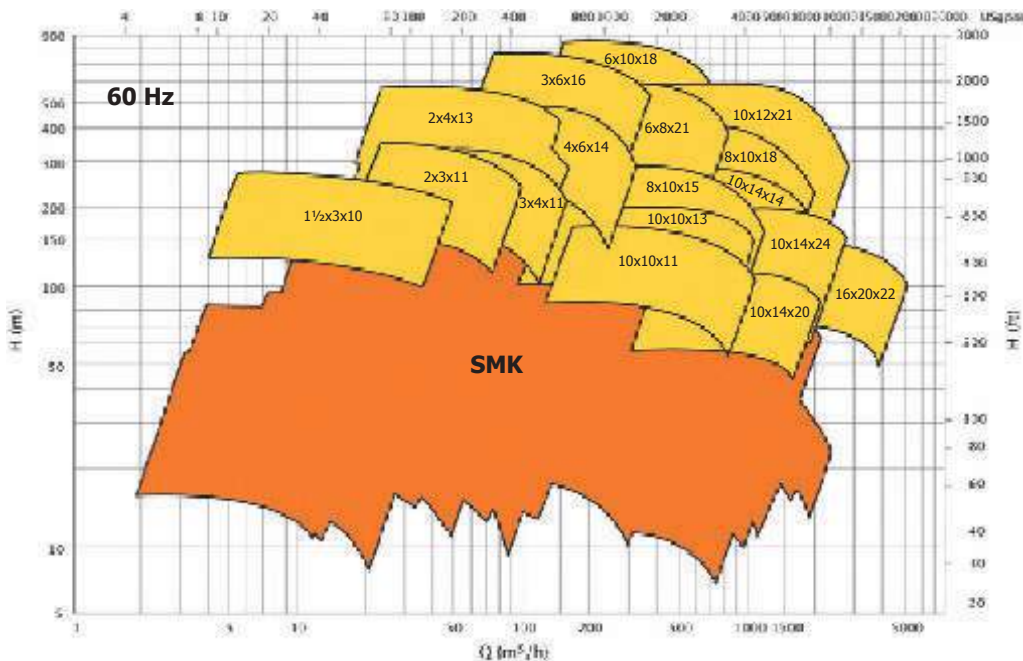
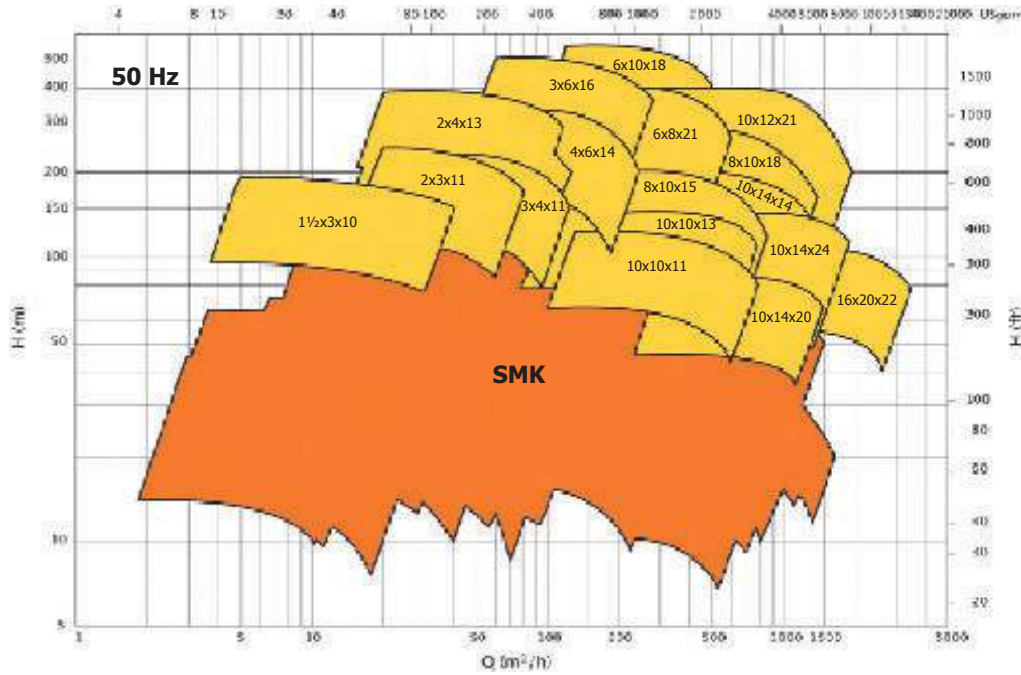

To locate the global representative, distributor or authorized service center nearest you, or for additional information please visit [www.sundyne.com](http://www.sundyne.com)

**GLOBAL STRENGTH**, powered by people.



Sundyne Headquarters:  
Sundyne, LLC  
14845 West 64th Avenue  
Arvada, Colorado 80007  
USA  
1-866-Sundyne  
Phone: 1 303 425 0800  
Fax: 1 303 940 2911  
[www.sundyne.com](http://www.sundyne.com)

Sundyne China:  
Building 1, No. 879 Shen Fu Road  
XinZhuang Industrial Zone  
Min Hang District  
Shanghai, China 201108  
Ph: +86 21 5055 5005  
Fax: +86 21 5442 5265

Sundyne France:  
Sundyne International S.A.  
13-15, Bld. Eiffel - B.P. 30  
21604 Longvic Cedex  
France  
Phone: +33 (0)3 80 38 33 00  
Fax: +33 (0)3 80 38 33 66

Sundyne Spain:  
Sundyne Marelli Bombas, S.R.L.  
Ctra. Madrid-Toledo, Km.30.8  
45200 Illescas  
Toledo, Spain  
Phone: +34 925 53 45 00  
Fax: +34 925 51 16 00

Sundyne United Kingdom  
Sundyne HMD Kontro Sealless Pumps, Ltd.  
Marshall Road  
Hampden Park Industrial Estate  
Eastbourne East Sussex, BN22 9AN  
United Kingdom  
Phone: +44 1323 452000  
Fax: +44 1323 503369

Worldwide Sales Headquarters  
Unit 2 Harvington Business Park  
Hampden Park Industrial Estate  
Brampton Road  
Eastbourne East Sussex, BN22 9BN  
United Kingdom  
Phone: +44(0) 1323 452125

All information provided is subject to change without notice.

© 2013 Sundyne, LLC  
All Rights Reserved. Other logos and trade names are property of their respective owners.