

**HPGSP Range**  
High Pressure Sealless  
Magnetic Drive Pumps  
API 685

**HMD Kontro**

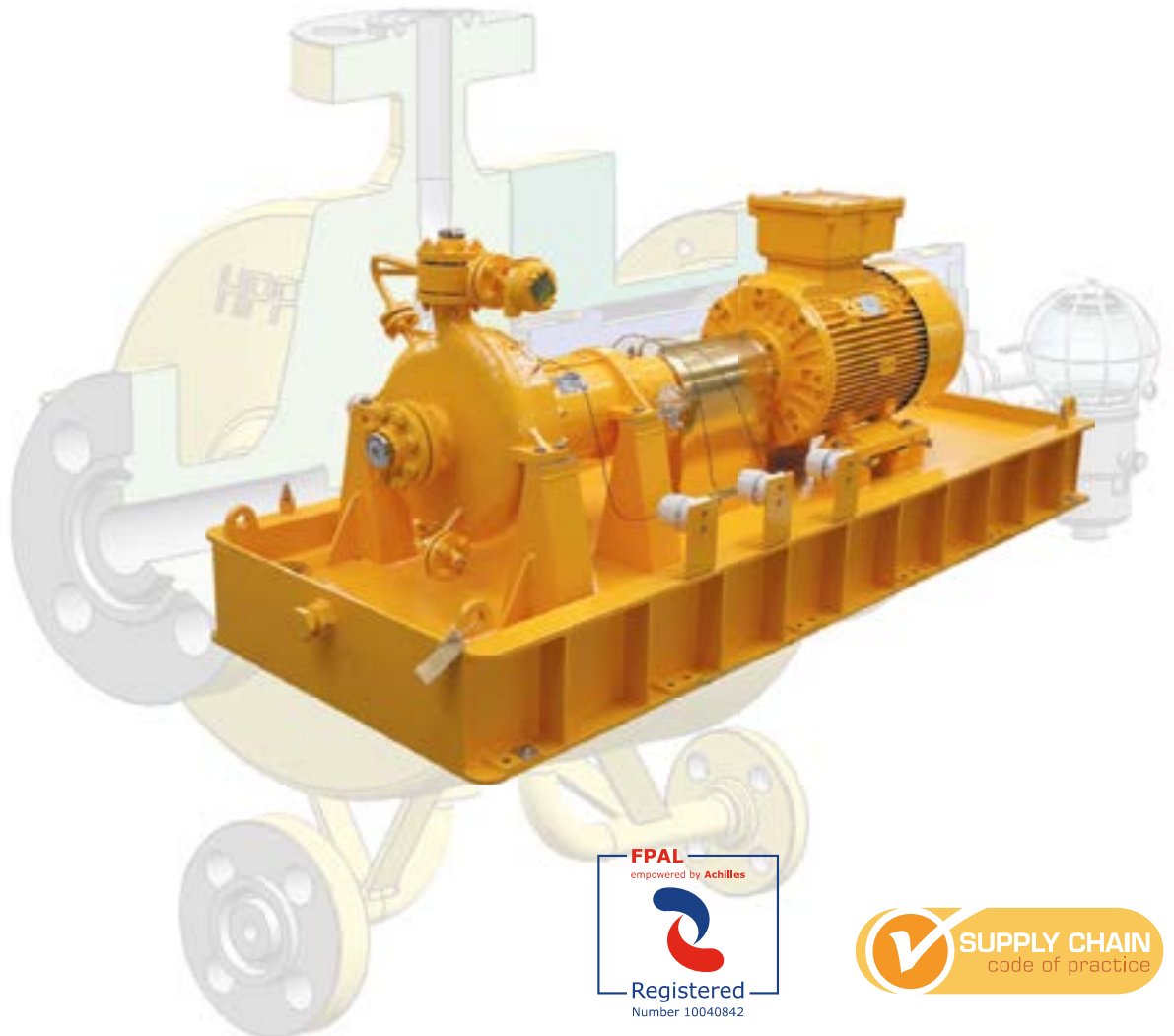

**Sundyne HMD Kontro**

# High System Pressure Sealless Pumps

**When your product is under pressure, the need for environmental, health and safety measures are amplified. Sundyne HMD Kontro HPGSP pumps can provide peace of mind in a variety of high pressure applications.**



Capable of easily handling high system pressures up to 2680 psi and higher, dependent upon temperature extremes, Sundyne HMD Kontro HPGSP pumps are exceptionally versatile yet safe and secure.

No seals means no leaks, less maintenance, reduced downtime and substantial cost savings. There really is no substitute to sealless.



### **Sundyne HMD Kontro High Pressure Sealless Pumps are the Solution**

HMD Kontro pumps are designed to comply with the requirements of API 685 specifications for magnetic drive, sealless end suction, centrifugal pumps required by the oil, gas, petroleum and heavy chemical industries.

Sundyne HMD Kontro have been building sealless magnetic drive pump units for the oil and gas industry since 1983. With increasing demands for the safety and welfare of personnel, plus the environment, these sealless pumps are playing an ever greater part in maintaining these goals. Improved magnet drive technology has enabled more efficient and powerful pumps, capable of handling high system pressures to be built, thus increasing the application scope for this technology.



Starting first with API 610 6th edition and then modifying designs to incorporate 7th and 8th edition requirements, we ensured that our sealless pumps met and exceeded the original requirements for sealed units. However, October 2000 saw the official release of API 685, a code dedicated to sealless pumps and once again Sundyne HMD Kontro was at the forefront of development with the GSP pump range. This has since been superseded by API 685 2nd edition, released in February 2011.

With over twenty-five years' API experience and our sixty five year heritage in magnetic drive technology Sundyne HMD Kontro is in an ideal position to provide your pump requirements for high pressure duties. Our range of pumps is being continuously developed and extended and currently stands at over thirty models.



In densitometer applications, the sampling pumps have to be able to take the full pressure from the main pipeline (up to 80 inches / 2 metres diameter) sample the liquid and then return it to the pipeline. System pressures of up to 2680 psi have to be contained, the cost of a mechanical seal able to handle these pressures would be considerable.

**Paragraph 9.1.2.1.3**  
Confined controlled  
compression gasket.

**Paragraph 9.1.3.5**  
Magnet rings are fully sheathed  
to prevent damage during  
assembly or disassembly.

**Paragraph 6.6.3**  
Renewable front and rear wear  
rings – located with locking  
pins (tack welded on request).

**Paragraph 6.2.9**  
Centerline mounted  
casing and coupling  
housing – provided  
as standard.

**Paragraph 6.3 / 6.4**  
Flanges and casings  
– full compliance to nozzle  
loading requirements.

**Paragraph 6.5.1 / 2 / 3 / 4**  
Impellers – fully enclosed,  
single-piece cast with solid  
hubs. Keyed to the shaft.

**Paragraph 6.3.3.5**  
Casing features flanged drain  
supported in two planes.

**Paragraph 6.1.10**  
All internal cavities are fully  
drainable – optional flush out or  
steam out connections available.

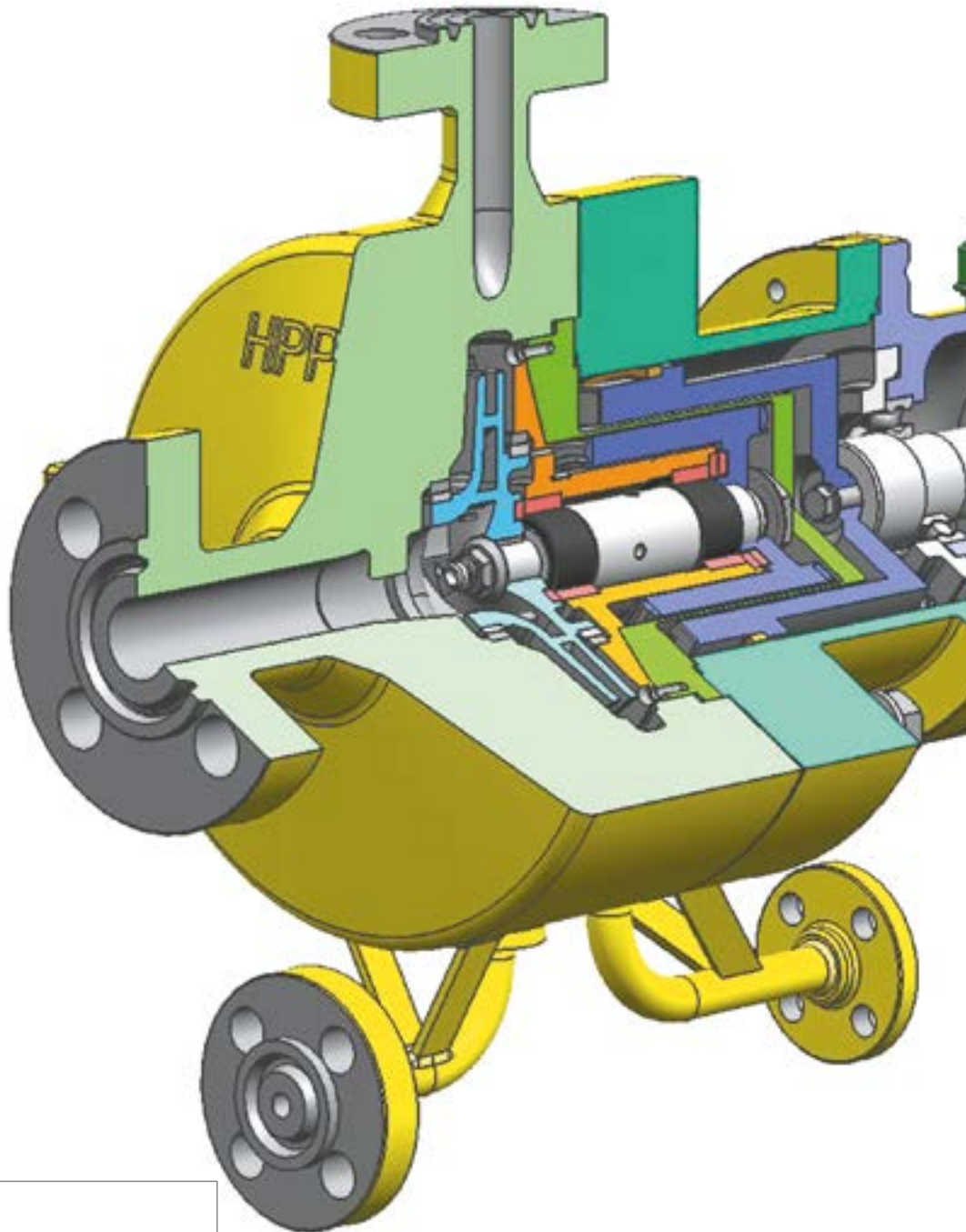

**KEY**

 Pump Casing	 Containment Shell
 Impeller	 Magnetic Drive
 Bush Holder	 Bump Ring
 Silicon Carbide Bushes	 Coupling Housing
 Silicon Carbide Shaft Sleeves and Thrust Washers	 Power Frame

**Paragraph 6.9.4**  
Sleeves – concentrically located  
bearing sleeves. Design  
compensates for relative thermal  
expansion. Concentrically located  
with O-rings.

**Paragraph 9.1.1.6**  
Internal bearings –  
not supported by the  
containment shell.

Note: Paragraph references refer to API 685 2nd edition.

### Paragraph 6.7

Secondary control / containment systems  
– full range available on request.

### Paragraph 6.9.9.1

Bearing housings supplied with  
dimples for vibration monitoring.

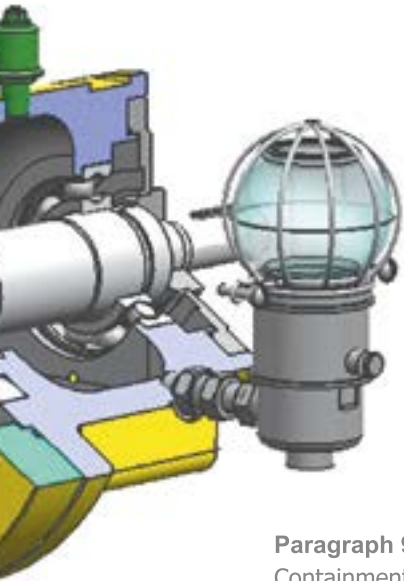

### Paragraph 9.1.2.1.1

Containment shell – constructed  
in accordance with ASME VIII  
international standards.

### Paragraph 6.9.7

Thrust bearings – designed for  
capacity in both directions.

### Paragraph 6.9.5

Grooved axial and radial  
bearings – for heat removal  
and particle flushing.

### Paragraph 6.9.6

Two radial bearings  
– provided as standard.

The HPGSP range meets and  
in many cases exceeds the  
requirements of API 685.

## Notes

**6.1.20** No cooling required for operating temperatures  
up to 660°F (350°C).

**6.1.26** Rapid and economical maintenance – shoulders  
and dowels to facilitate assembly and disassembly.

**6.1.3.4 / 6.1.3.7** Temperature and pressure profiles –  
heat balance calculations provided.

**6.2.2** Pressure casings, flanges and coupling housings  
rated for 580 psi (40 bar) – for the HPGSP the pressure  
casing is up to 2680 psi (185 bar).

**6.2.12** No tapped holes in the pressure boundary.  
Flanged connections supplied as standard.

**6.10** Materials – HPGSP pumps are available as  
standard with S-5, S-8, D-1 and D-2 materials. Other  
variations are available on request.

**6.10.3** Welding in compliance with ASME  
section VIII, Div 1, and section IX.

**7.6** Special tools – not required for  
maintenance of HMD Kontro GSP pumps.

**9.1.3.2** All magnetic couplings feature mechanically  
retained and bonded magnets.

**9.1.3.5** Outer magnet rings have non-magnetic metallic  
sheathing to protect exposed magnets.

**9.1.3.3** All units feature a non-sparking bump ring to  
prevent outer magnet ring contacting containment shell  
in the event of an external bearing assembly failure.

**9.1.4** Antifriction bearing assemblies – fully compliant  
rolling element bearings, sized in accordance with  
requirements.

**9.1.5.3** Baseplate – heavy duty design incorporates  
continuous welds, leveling screws, lifting lugs, grout  
locking cross-members and drain connection.

NORSOK compliance available on request.

**Sundyne HMD Kontro**

## A history of complying with API requirements

**Sundyne HMD Kontro pioneered the first sealless, magnetic drive pump over sixty five years ago. Therefore, it has been natural that the company should be at the forefront of development for API 685 applications.**



Sundyne HMD Kontro installed the first API magnetic drive centrifugal pump in 1983 at a major blue-chip oil company in Australia. These were followed shortly by further installations with BP in Norway. At that time the American Petroleum Institute did not have a specific standard that applied to sealless pumps. Therefore the first Sundyne HMD Kontro API pumps were designed to follow the then current standard.

It started with API 610 – Centrifugal Pumps for Petroleum, Petrochemical and Natural Gas Industries. As much of the API 610 standard concerns seal and seal support systems, a considerable portion of the specification was not applicable to Sundyne HMD Kontro sealless API pumps.

In 2000 the American Petroleum Institute launched the API 685 standard for Sealless Centrifugal Pumps for Petroleum, Heavy Duty Chemical and Gas Industry Services. At this time, sealless technology had become well accepted in the chemical processing industry, but had not been as widely accepted in the refinery and petroleum industries. This was partly due to the lack of an API specification specifically addressing sealless designs.

Since 1983 many successful API 610 and 685 Sundyne HMD Kontro magnetic drive pump installations have been implemented with clients worldwide on a huge variety of different applications. As a result, a substantial reference list is available.

The HPGSP range of pumps is designed to comply with all of the requirements of API 685 – Sealless Centrifugal Pumps for Petroleum, Heavy Duty Chemical and Gas Industry Services including the latest edition of the standard published in February 2011.



**Sundyne HMD Kontro**

**High Pressure**

# Magnetic Drive Pumps to API 685

Magnetic drive sealless pumps offer significant advantages and benefits over conventional sealed designs:

- No seals
- No seal support systems
- Complete fluid containment
- Zero emissions
- Zero contamination of pumped liquid
- Cost effective installation
- No ancillary seal support systems to specify and install
- Longer mean time between failure (MTBF)
- No EPA monitoring required
- Improved operator safety and protection of the environment

Mechanical seals are widely regarded as the weakest point in any pumping system using them. Over 85% of pump failures involve mechanical seal failure and/or leakage through static seals such as gaskets and/or O-rings and bearing failure.

When planning a new pump installation or an upgrade to an existing site, often the financial impact of the mechanical seal support system is considerable. Additional design time, utility provision, installation and commissioning is required. Once such a system is installed, further cost implications are caused by the need for new seals, replacement of barrier fluids and ongoing maintenance. Also the need to comply with local, regional or national environmental requirements, which often involve monitoring the effectiveness of such a system.

By completely eliminating the seal and associated seal support system, the Sundyne HMD Kontro HPGSP range of pumps are ideal for handling liquids with the following characteristics:

- Toxic
- Lethal
- Carcinogenic
- Flammable
- Expensive Fluids
- Fluids containing dissolved solids (i.e. caustic)
- Fluids containing H<sub>2</sub>S (sour water)
- Heat Transfer Fluids (cold and hot)
- High Vapor Pressure Liquids

If your staff, local environment or your reputation are at risk from the above then ensure you install Sundyne HMD Kontro sealless pumps.



**Sundyne HMD Kontro**

**The HPGSP**

## **Pump Range**



The HPGSP range comprises pumps based on the Sundyne HMD Kontro GS drive, built to API 685 specification, suitable for heavy-duty applications.

- Separate mounted design available in thirteen hydraulic sizes
- Two basic frame sizes to suit power requirements
- No costly seal support systems to specify, install or maintain
- Large degree of interchangeability within frame sizes
- Commonality minimizes spare parts inventory and associated costs
- Centre line mounted design with support brackets on the casing to minimize vibration and allow for thermal expansion
- Mounted on a heavy-duty fabricated steel drip pan baseplate
- Self-venting and completely self-draining
- Conforms to API 685 for sealless pumps and relevant API 610 requirements
- Design ensures safe, leak free operation
- Increased efficiency via low operating costs
- Reduced specification time and installation costs
- Standard materials of construction per S-8 and S5, D-1 and D-2. Other variations are available on request
- Silicon carbide internal bearings
- Various flange options are available as standard
- Full range of secondary control / containment systems available on request
- Wide range of instrumentation systems available
- VapourView® 'gas in liquid' detection





### Essential Sundyne HMD Kontro Benefits

- High efficiency magnet drive
- Almost zero unplanned maintenance
- Absolutely no leakages
- Environmentally safe
- System pressures up to 2680 psi / 185 bar (higher pressures available upon request)
- Fully encapsulated magnets
- Heavy-duty power frame
- ASME VIII containment shell
- High system pressure capability without 'backup' systems
- Standard electric motors utilized
- No cooling required up to 660°F / 350°C
- Material options available
- Alpha SiC internal bearings
- Non sparking bump ring for safety
- Sundyne HMD Kontro worldwide service support

### Typical Applications Include:

- Booster Packages
- Pipeline Injection
- Monitoring and Sampling
- Densitometers
- Remote Locations
- Tanker Offloading (Road and Rail)
- Heavy Duty Chemical Applications
- Hot Oil Circulation
- Petrochemical Processing Plants

### Liquids Handled by GSP Pumps:

The following is a sample of some of the typical liquids that the HMD Kontro GSP API 685 pumps have been used for:

Acrylic Monomers	Methanol
Acrylonitrile	MEG
Alkylate	Methylene Dichloride
Amyl Acetate	Methyl Mercaptan
Anhydrous HF	Methyl Naphthalene
Amines	MMA
Aromatics	Naphtha
Benzene	Naphthalene
Butadiene	Pentane
Butane	Phenol
Caustic Soda	Produced Water
Chloroform	Pyridine
Condensate	Sour Water
Crude Oil	Styrene
Cyclohexane	Sulphuric Acid
Dichlorobenzene	TDA
Ethylene	TDI
Hexane	Thermal Oil
Hydrocarbons	Toluene
Hydrofluoric Acid	Trichloroethylene
Kerosene	Vinyl Acetate
Isobutane	Various Chlorinated
Iso-Propyl Alcohol	Hydrocarbons
LPG	Xylene
MDI	

The above list is not exhaustive. Please contact us for reference and information for many other liquids successfully handled.



### HPGSP Hydraulic Coverage

Head	Flow	Temperature	Design Pressure*
715 ft	1540 USgpm	-150 to 500°F	2680 psi
220 m	350 m <sup>3</sup> /h	-100 to 260°C	185 bar

\* Design pressures for larger pumps are 1450 psi (100 bar). Higher pressures are available upon request. Internal pressure / temperature profiles available. Optional instrumentation packages available

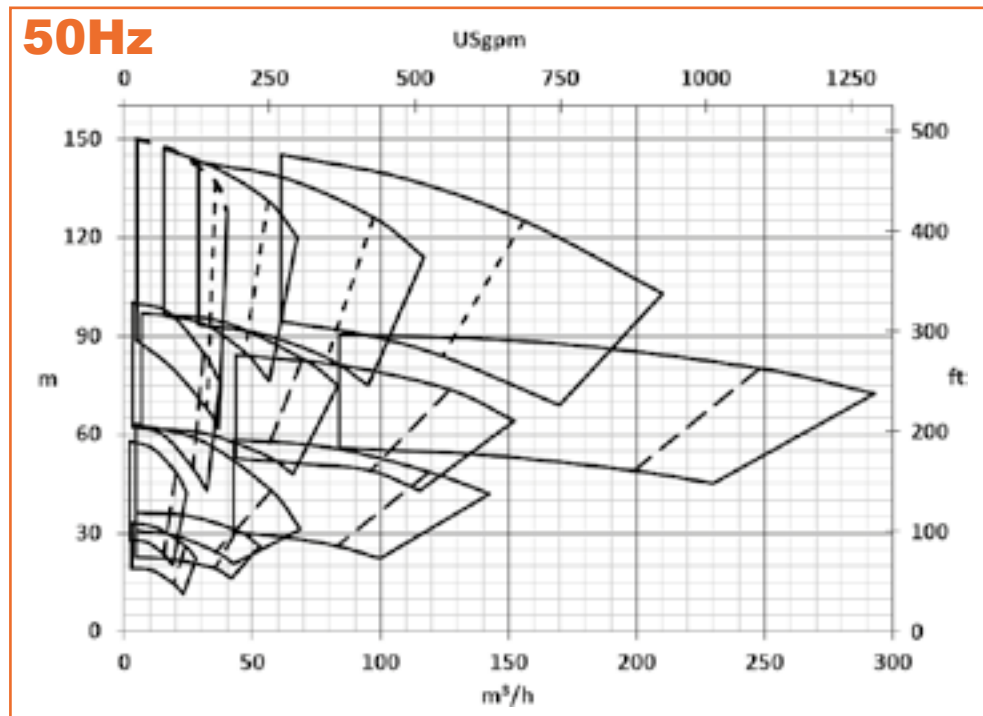
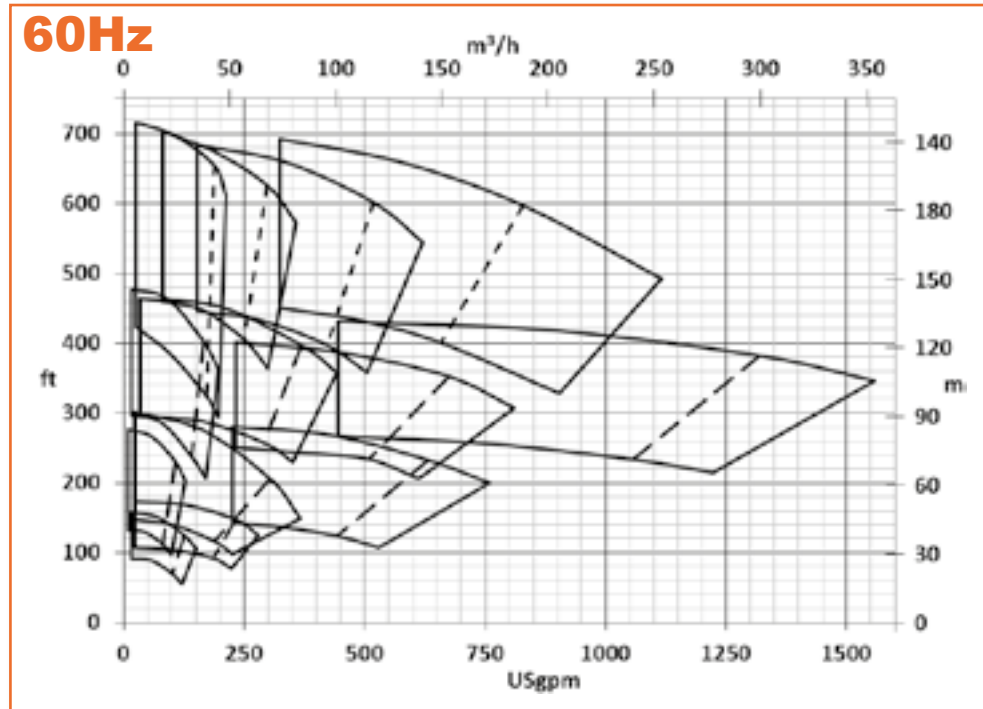

### Sealless Savings

Specifying sealless, magnetic drive pumps can save significant costs both in respect of time and money. Indeed, a major feature is that savings can be made before, during and after installation, with reduced running costs.

Having no seal system, and consequently no ancillaries, means that design and engineering time as well as the time taken for procurement is significantly reduced. At the time of installation, commissioning is quicker, allowing faster project completion and there are far less lengthy HazOps (Hazard and Operability) studies to undertake, endure and agree, thanks to the much simpler design of the sealless pump.

Once up and running, sealless pumps really come into their own. Reduced downtime, because of less maintenance and no need for seal changes, contributes to much improved plant utilization and hence profitability.

The simple design of a sealless pump, together with a proven track record, provides a 'fit and forget' advantage. Not only is maintenance much reduced but also there is less need to keep spare parts, in particular, there are no seals to stock, and the need for skilled labour overhead is also reduced.

### Sealless Safety

With a magnetic drive pump there is no opportunity for leaks or emissions. Therefore, your Environmental Health & Safety personnel will like the fact that you specified sealless.

Because there are no seals, and the resultant leak path, required to lubricate the seal, there is no need for EPA monitoring and much less risk to operational personnel on your job site.

No requirement for support systems and the fact that no barrier fluids need to be used means much reduced possibility of accidents and emissions. It also reduces liabilities and can hence also help to lower insurance costs.

Overall, sealless pumps represent better operator safety, a cleaner working environment and reduced potential for legislation and litigation.



### Sealless Service

Although our pumps only require minimal maintenance, that does not mean there is no after sales service from Sundyne HMD Kontro. Quite the opposite in fact.

Our own After Sales team, together with our partners around the world, can help to optimize the performance and through life experience of using Sundyne HMD Kontro pumps. From assisting with installation and commissioning, including ensuring smooth contract execution and swift provision of all the appropriate documentation, through to optimizing your spares inventory and operating efficiency using the benefit of our experience.

Extending MTBF (mean time between failure) and providing you with the appropriate parts to effect fast maintenance and quick replacement where necessary, will significantly assist in reducing downtime and minimizing through life costs, which are already inherently low with an Sundyne HMD Kontro pump.

**To learn more about why sealless is so suitable for your high pressure application, please contact us, either directly or through your country partner, which can be found on [www.sundyne.com](http://www.sundyne.com). We look forward to helping sealless be of service to you.**

### Existing

#### Users Include:

Apache  
Aramco  
BP  
British Gas  
Conoco Phillips  
Chevron  
Esso  
Exxon Mobil  
Jiskoot  
LukOil  
Maersk  
Marathon  
OMV  
Petrobras  
Petronas  
Pemex  
Repsol  
Sasol  
Shell  
Solartron  
Statoil  
Sunoco  
Talisman  
Texaco

Sundyne Headquarters:

#### Sundyne, LLC

14845 West 64th Avenue  
Arvada, Colorado 80007  
USA  
1-866-Sundyne  
Phone: 1 303 425 0800  
Fax: 1 303 940 2911  
[www.sundyne.com](http://www.sundyne.com)

Sundyne United Kingdom:

#### Sundyne HMD Kontro Sealless Pumps

Marshall Road  
Hampden Park Industrial Estate  
Eastbourne, East Sussex, BN22 9AN  
United Kingdom  
Phone: +44 (0)1323 452000  
Fax: +44 (0)1323 503369

Sundyne China:

#### Sundyne Industrial Equipment (Tianjin) Company Limited

Building 1, No. 879 Shen Fu Road  
XinZhuang Industrial Zone  
Min Hang District  
Shanghai, China 201108  
Phone: +86 21 5055 5005  
Fax: +86 21 5442 5265

Sundyne France:

#### Sundyne International S.A.

13-15, Bld. Eiffel - B.P. 30  
21604 Longvic Cedex  
France  
Phone: +33 (0)3 80 38 33 00  
Fax: +33 (0)3 80 38 33 66

Sundyne Spain:

#### Sundyne Marelli Bombas, S.R.L.

Ctra. Madrid-Toledo, Km.30.8  
45200 Illescas  
Toledo, Spain  
Phone: +34 925 53 45 00  
Fax: +34 925 51 16 00

#### Worldwide Sales Headquarters

Unit 2 Harvington Business Park  
Brampton Road  
Hampden Park Industrial Estate  
Eastbourne East Sussex, BN22 9BN  
United Kingdom  
Phone: +44 (0)1323 452125

All information provided is subject to change without notice.

© 2015 Sundyne, LLC  
All Rights Reserved. Other logos and trade names are property of their respective owners.

Sundyne HMD Kontro HPGSP  
1.1 3/15 Letter.

To locate the global representative, distributor or authorized service center nearest you, or for additional information please visit [www.sundyne.com](http://www.sundyne.com)

**GLOBAL STRENGTH,** *powered by people*