

The GSPX magnetic drive pump is a multi-stage, API 685, BB5 design.

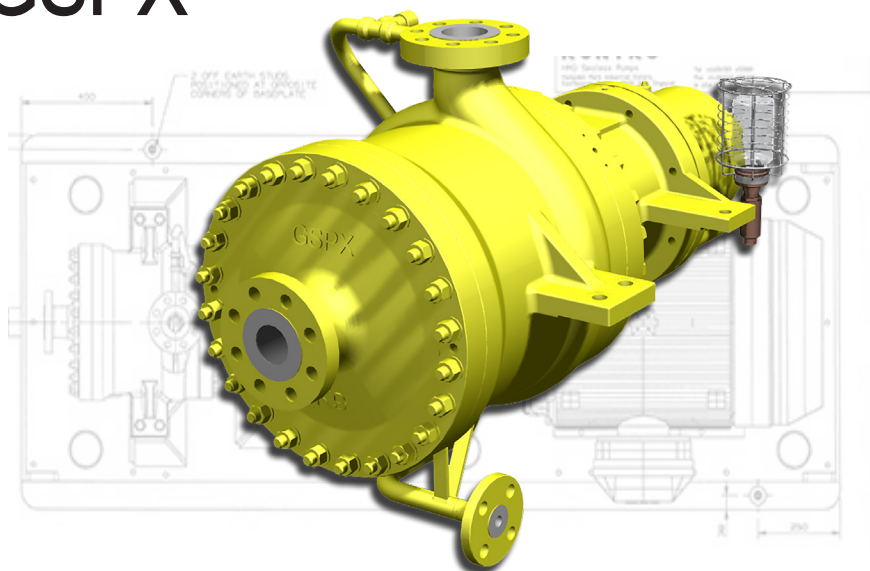

# GSPX



The GSPX magnetic drive pump is a multi-stage, API-685, BB5 design that is ideal for oil and gas installations, plus chemical and petrochemical applications.

- Heads to 1400 ft (295m)
- Flows to 440 gpm (62 m<sup>3</sup>/hr)
- Temperature Range: -40 to 500 F (-40 to 260 C) Standard
- Max Case Pressure up to 725pia (50 Bar)

The GSPX produces higher differential pressures than our single-stage sealless models.

## Specifications

Heads To	0 to 1,400 ft	0 to 295 m
Flows To	0 to 440 gpm	0 to 85 m <sup>3</sup> /hr
Max Power	0 to 167 hp	0 to 125 kW
Temperature Range	-40 to 401°F	-40 to 260°C (Higher temps with options)
Number of Stages	2 or 3 stages	
Max Case Working Pressure	580 psi	40 bar (725 psi [50 bar] available)
Max Suction Pressure	Depends on duty, see max working pressure	
Differential Head	1,400 ft	295 m
HP Dependent on Diff. Head	167 hp	125 kW
Standard Delivery	8-12 Weeks	
Materials of Construction	S-5, A-8, alternative materials available on request	
Bearing Materials Available	Silicon Carbide internal journal and thrust bearings	
Hydrotest Pressure	870 psi	60 bar (1087 psi [75 bar] available)
Max Viscosity	200 cst	
Industry Standard	API-685, BB5	
Solids Range	maximum of 5% w/w with less than 150 microns	
Motor Details	To suit duty power	
Mounting Configurations	Separate Mount	
Number of Available Hydraulics...	4 (2 or 3 stage K9, 2 or 3 stage K11)	
Available Inducer	Yes	
Available Flanges	ANSI B16.5 RF, 300lb standard. 600lb option	
Pump Case Corrosion Allowance	0.118 inch (3 mm)	
Suction and Discharge Size	3 in. or 2 in. suction, 2 in. discharge, 3/4 in flanged drain connection	

## APPLICATIONS

- Petroleum Production
- Petrochemical Processing
- Refining Chemical Processing



## Sealless Centrifugal Pumps API 685

The GSPX is a sealless magnetic drive horizontal end suction metallic centrifugal pump which meets API-685 and API-610 standards. This pump is highly reliable for high temperature, high viscosity, high pressure and hazardous chemical process applications. Sealless pumps have no seals, and therefore no possibility of leaks, making them safe and reliable. Sealless centrifugal pumps are perfect for difficult to seal, hazardous, and high-value applications for petroleum, heavy duty chemical processing and refining, and gas industry services.

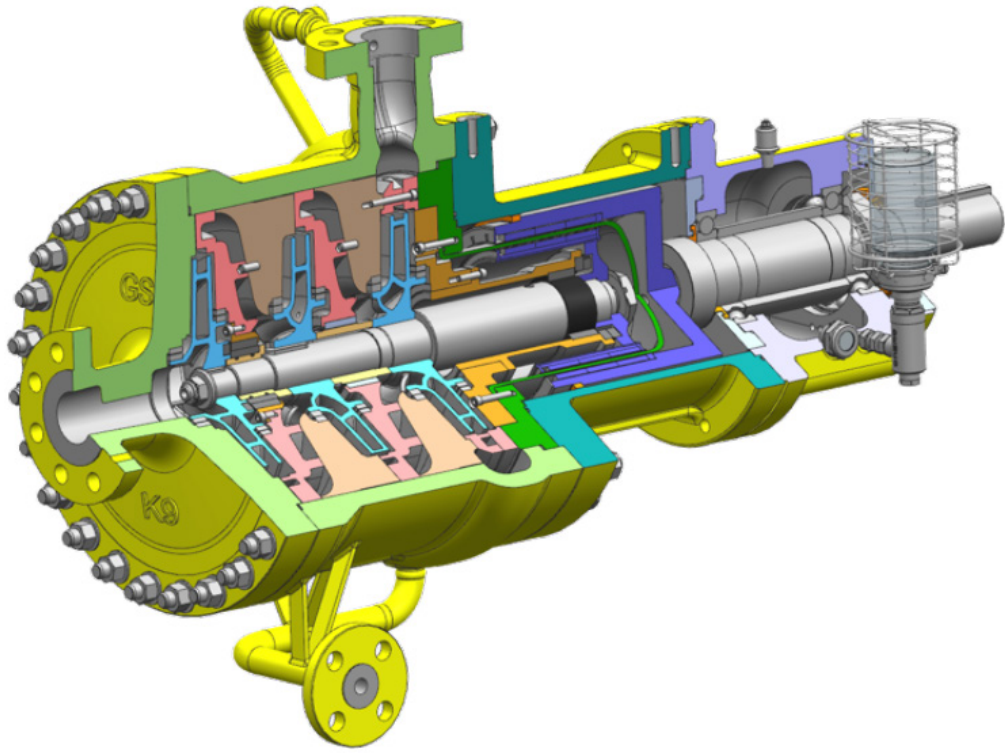

## PERFORMANCE

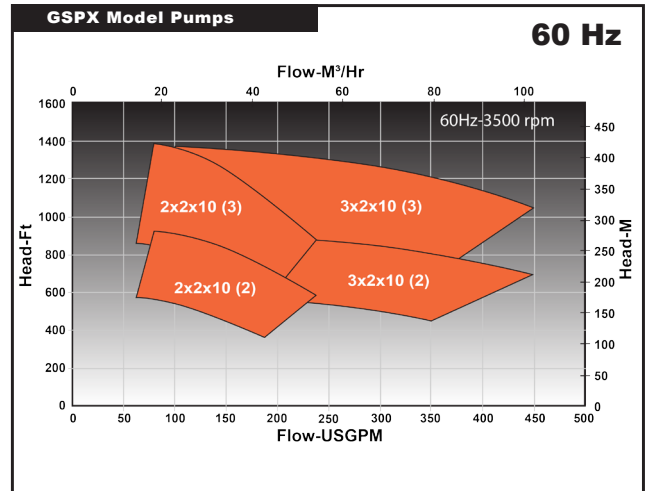
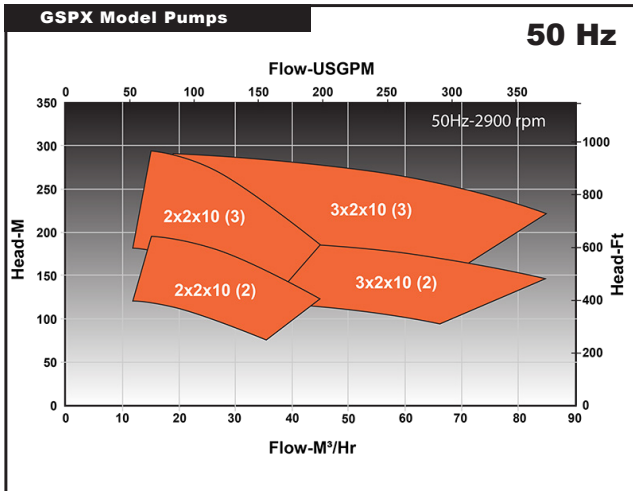

Visit our website at: [www.sundyne.com](http://www.sundyne.com)

Sundyne Headquarters: Sundyne, LLC 14845 W. 64th Ave. Arvada, CO 80007 USA 1-866-SUNDYNE (US and Canada) Ph: +1 303 425 0800 Fax: +1 303 425 0896

Sundyne China: Bldg. 1, No. 879 Shen Fu Road, XinZhuang Industrial Zone, Min Hang District, Shanghai, China 201108 Ph: +86 21 6121 1600 Fax: +86 21 5442 5266

Sundyne France: Sundyne International S.A. 13-15, Bld. Eiffel - B.P. 30 21604 Longvic Cedex France Ph: +33 (0)3 80 38 33 00 Fax: +33 (0)3 80 38 33 66

Sundyne Spain: Sundyne Marelli Bombas, S.R.L. Ctra. Madrid-Toledo, Km.30.8 45200 Illescas Toledo, Spain Ph: +34 925 53 45 00 Fax: +34 925 51 16 00

Sundyne United Kingdom: Sundyne HMDKontro Sealless Pumps, Ltd. Marshall Rd Hampden Park Industrial Estate Eastbourne East Sussex, BN22 9AN UK Ph: +44 1323 452000 Fax: +44 1323 503369

© 2013 Sundyne, LLC All rights reserved. Other logos and trade names are property of their respective owners. GSPX\_DS\_A4\_POD\_v1.0\_072914