

# THE VERTICAL EXPERTS



When space is at a premium, take it vertical.



**RELIABILITY  
REALIZED.**

# SUNDYNE HAS A PRECISION ENGINEERED VERTICAL PUMP FOR JUST ABOUT ANY PROCESS CHALLENGE.

*A compact vertical footprint from Sundyne saves you as much as 25% space, when space is critical.*

## Sundyne – THE Vertical Experts

At Sundyne, we've long realized the benefits of vertically configured fluid handling solutions; not only do vertical pumps boast a more compact footprint perfect for operations where space is at a premium, they are also easier to install and maintain while delivering the same level of performance as typical horizontal designs. And with a wide variety of configurations and power ratings.

Featuring heavy duty construction, advanced parts metallurgy and the capability to deliver a broad range of heads and flows, Sundyne vertical pumps are also built to meet exacting **API 610 and 685** specifications, meaning that they deliver the rugged reliability upon which Sundyne built its reputation.

ASME / ANSI B73.2 vertical single stage sealless non-metallic, ETFE-lined magnetic drive centrifugal pump.



GSPV vertical inline sealless magnetic drive API 685 pump.



NEW!  
LMV-801S Sealless centrifugal API 685, centrifugal pump.



LMV-801 Sealed Direct drive centrifugal ISO 13709, API 610, 10th Edition, OH3/OH5 pump.



LMV-3XX gear driven centrifugal ISO 13709, API 610, 10th Edition, OH6 pump.



GSPVS vertical sealless magnetic drive, API 685, sump pump.

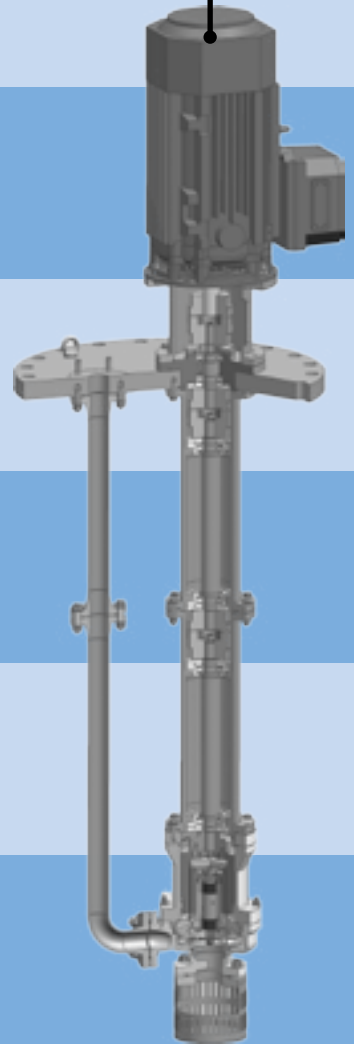

UPGRADE YOUR LMV-801 SEALED DIRECT DRIVE WITH THE NEW LMV-801S SEALLESS MAGNETIC DRIVE PUMP  
*(without changing your piping)*

Rugged reliability in a compact footprint; equating to maximized uptime, reduced maintenance costs and optimized productivity over the lifecycle of the unit.

SCALE: 3 FT (914 MM)

(most vertical pump lengths are variable)

FG API 610, 11th Edition (VS1) ISO-13709 vertical suspended, multi-stage pump.

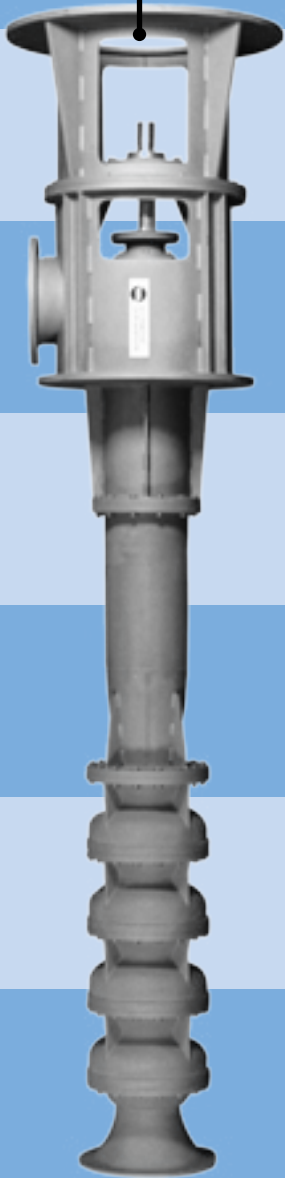

FQ API 610, 11th Edition (VS2) vertical mounted, double suction impeller, centrifugal sump pump.

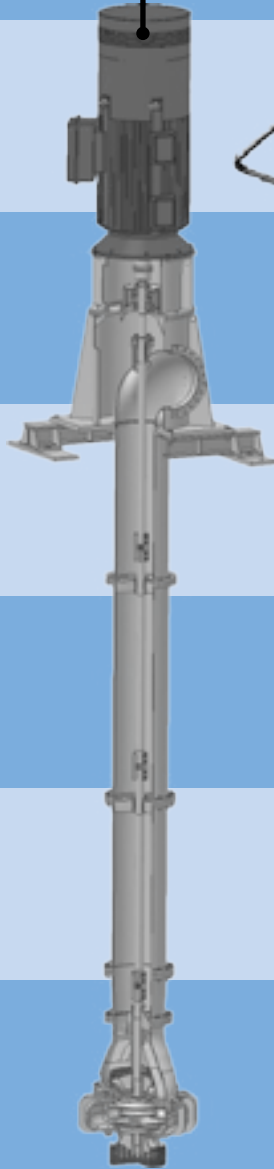

VSMK and VSMKD API 610, 11th Edition (VS4) submersible pump.

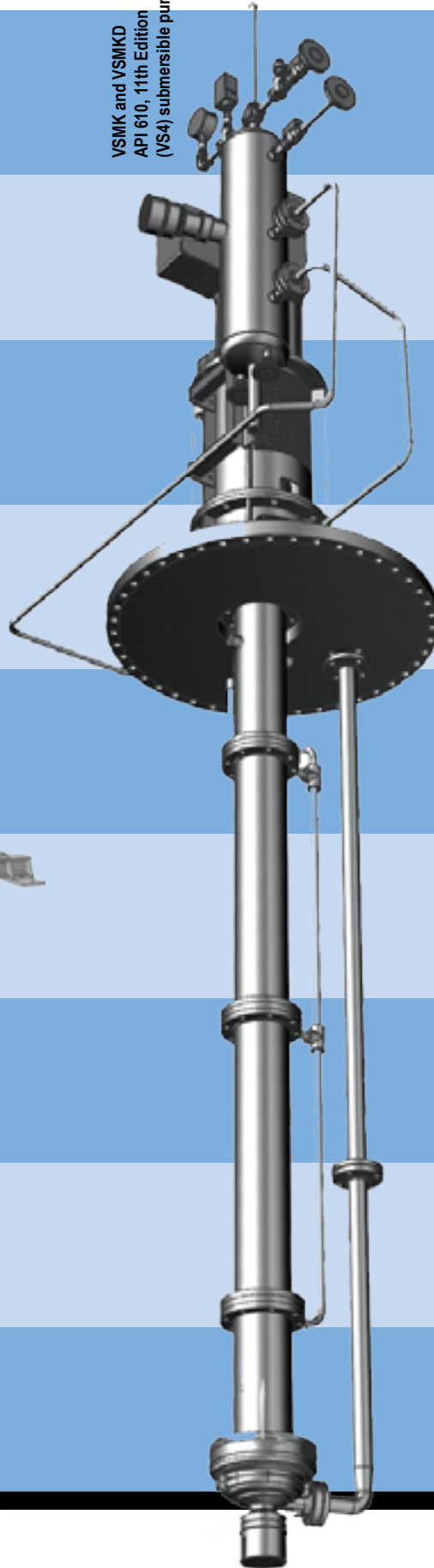

FGB API 610, 11th Edition (VS6) ISO-13709 vertical can, multi-stage submersible pump.

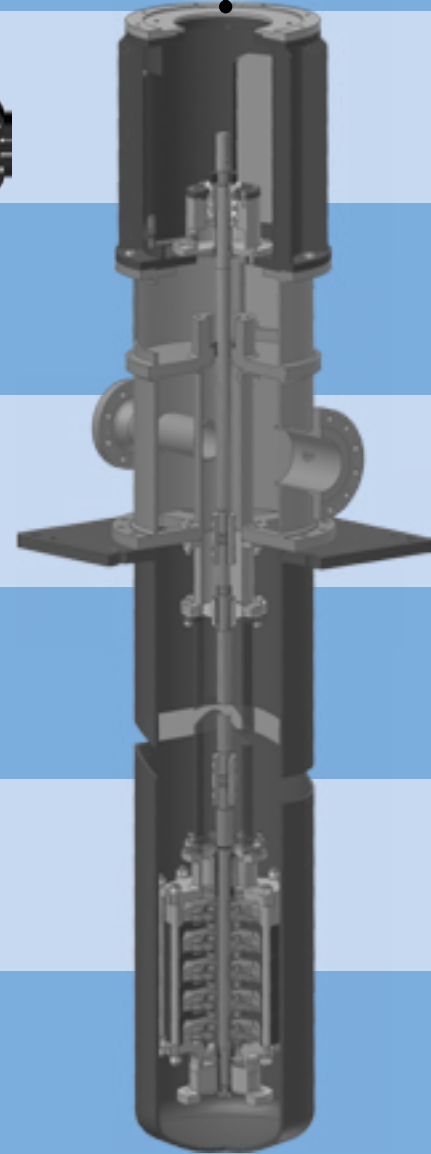

# Let's Get Vertical.

## Packaging Your Vertical System

Sundyne specializes in the design and manufacture of highly engineered skid packaging tailored to your specific application, API, ISO, or ANSI standards and process piping requirements.

Our platforms are designed and manufactured with thick casing, robust seal designs, bearings, shafts and gears designed to run for more than 5 years without overhaul or repair – keeping your personnel, facilities and the environment safe.

### To Learn More

Locate and contact your local channel partner at [www.sundyne.com](http://www.sundyne.com).

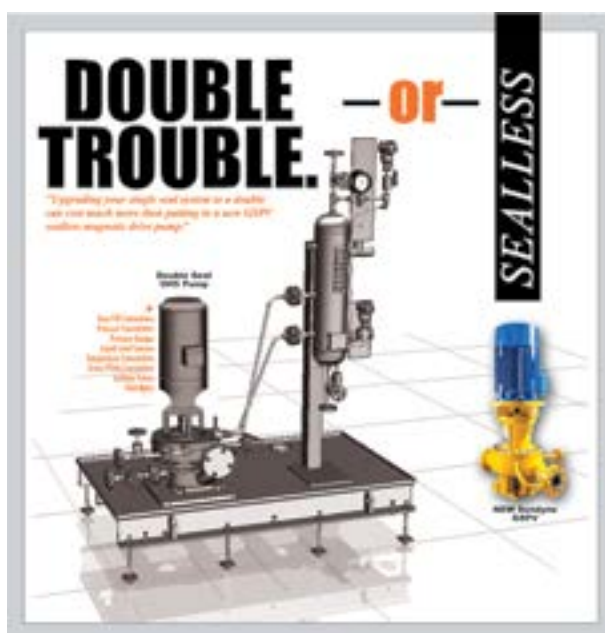

Save money and as much as 25% space today with a compact footprint!



**RELIABILITY  
REALIZED.**

Visit our website at: [www.sundyne.com](http://www.sundyne.com)

Sundyne Headquarters: **Sundyne, LLC** 14845 W. 64th Ave. Arvada, CO 80007 USA 1-866-SUNDYNE (US and Canada), Ph: +1 303 425 0800 Fax: +1 303 425 0896

Sundyne China: Building 1, No. 879 Shen Fu Road, XinZhuang Industrial Zone, Min Hang District, Shanghai, China 201108, Ph: +86 21 5055 5005 Fax: +86 21 5442 5265

Sundyne France: **Sundyne International S.A.** 13-15, Bld. Eiffel - B.P. 30 21604 Longvic Cedex France Ph: +33 (0)3 80 38 33 00 Fax: +33 (0)3 80 38 33 66

Sundyne Spain: **Sundyne Marelli Bombas, S.R.L.** Ctra. Madrid-Toledo, Km.30.8 45200 Illescas Toledo, Spain Ph: +34 925 53 45 00 Fax: +34 925 51 16 00

Sundyne United Kingdom: **Sundyne HMDKontro Sealless Pumps, Ltd.** Marshall Rd Hampden Park Industrial Estate Eastbourne East Sussex, BN22 9AN UK Ph: +44 1323 452000 Fax: +44 1323 503369

©2016 Sundyne, LLC. All rights reserved. Logos and trade names are property of their respective owners. Vertical Experts Brochure\_A4\_v3.0\_062916; POD