

MIDSTREAM

Safe, reliable, compact, efficient and compliant production.

Proven Pumps
and Compressors
For Midstream Applications

SUNDYNE is the global leader in
LOW FLOW, HIGH HEAD pumps
and compressors for onshore and
offshore oil and gas production.



**Sundyne**

Sundyne Pumps & Compressors for Midstream Applications

Natural gas is a naturally occurring hydrocarbon formed by intense heat and pressure under the earth's surface over millions of years. It was initially discovered in China in 500 B.C. and first extracted on an industrial scale in New York in 1825. Over the last several years, the volume of proven reserves has increased substantially, creating new opportunities for upstream and midstream producers.

Global Natural Gas Production

Rank	Country	Natural gas - production (cubic meters) January 2018 (Source IndexMundi)
1	United States	766,199,988,224
2	Russia	598,599,991,296
3	Iran	184,800,002,048
4	Qatar	164,000,006,144
5	Canada	149,900,001,280

In addition to providing the feedstocks for chemicals and plastics, natural gas is increasingly becoming the feedstock of choice for power generation. As developing nations in Asia, Africa and other parts of the globe mature, energy demand is predicted to increase by as much as 45-percent. Solar, wind, and biofuel renewables are expected to meet about 5-percent of this new demand - But current forecasts suggest that up to 40-percent of the world's new energy demand over the next 20 years will be met by natural gas.

In the United States, gas has surpassed coal as the single biggest source for power generation, and the trend is catching on globally, as most new power plants use gas as a feedstock, for several reasons:

- Abundance of supply
- Favorable economics
- New efficiencies in LNG processing – enabling global transport
- Ease of domestic transport via pipeline
- Environmental efforts to minimize carbon emissions
- Gas plants require far less water for cooling purposes than nuclear or coal plants

Global Electricity Production

Rank	Country	Electricity - production (billion kWh)
1	China	6,142
2	United States	4,088
3	India	1,289
4	Russia	1,008
5	Japan	976.3



**Sundyne Pump
(Deethanizer Booster)**



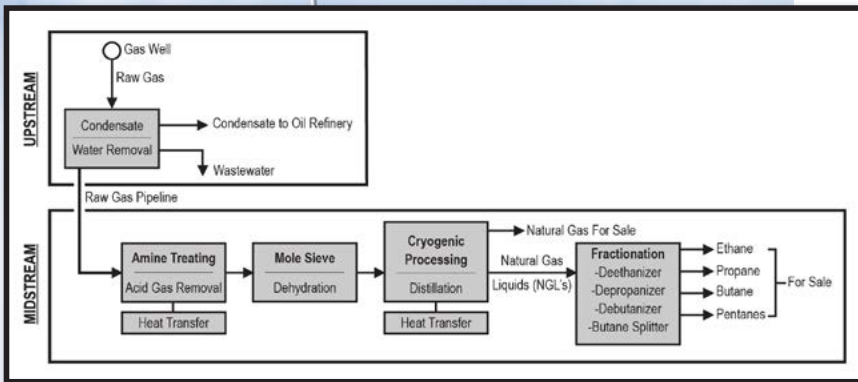

Increasing Demand for Midstream Gas Processing:

Oil and natural gas are often found together in the same reservoir, and different well types (crude, gas, or condensate wells) produce different types of sweet, sour or acid gases. Processing activities begin at the wellhead by removing water and contaminants, and are continued by midstream companies, which operate pipelines and gathering facilities.

Common midstream processing applications include:

- **Amine Treating**, to remove acid gas.
- **Molecular Sieve dehydration**: Natural Gas condenses to LNG at -260°F (-160°C), and water freezes at just 32°F (0°C), so wet natural gas must be dehydrated to prevent ice from forming.
- **Cryogenic processing & distillation**, to separate natural gas liquids (NGLs).
- **Fractionation applications**, which remove carbon atoms and separate heavier hydrocarbons (ethane, propane, and butane) from the gas stream: Once separated, each component is sold as a usable by-product or feedstock.

The process of removing all additional carbon atoms from the gas stream produces methane, which is pipeline-quality dry natural gas. Once processed, Methane is distributed to downstream consumers (used as a feedstock for power generation), and it can also be compressed or liquefied.



Sundyne Compressor (Regenerating Dehydration Towers)

Simple Hydrocarbons and Their Variations

# Carbon atoms	Name (single Bond)	Double Bond	Common uses
1	Methane	-	Natural Gas, electricity generation
2	Ethane	Ethene	Feedstock for plastics
3	Propane	Propene	Fuel, Cooking
4	Butane	Butene	Gas blending, Chemical manufacturing (Rubber)
5	Pentane	Pentene	Solvents, foams
6	Hexane	Hexene	Glue, leather, textiles
7	Heptane	Heptene	Solvents, paints, coatings
8	Octane	Octene	Gasoline/Petrol
9	Nonane	Nonene	Jet Fuel, kerosene
10	Decane	Decene	Kerosene and gasoline components
11	Undecane	Undecene	Bug spray, household chemicals

Sundyne Pumps & Compressors in Midstream Applications

AMINE TREATING:

Amine gas treating utilizes various alkylamine solutions to remove hydrogen sulfide and carbon dioxide from natural gas. Midstream plants treat raw gas transported from the wellhead to produce sweet gas for further processing.

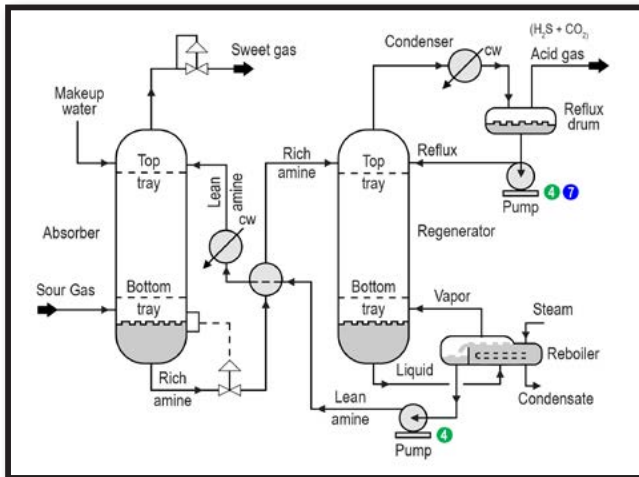

Sundyne sealless magnetic drive API-685 Centrifugal pumps are commonly used in the reflux and lean amine processes. These types of applications can pose challenges to pump seals by creating magnetic losses and by heating the process fluid. But Sealless magnetic drive pumps from Sundyne HMD Kontro overcome these challenges through containment shells which eliminate eddy current losses in the pump and reduce energy consumption. With no seals to repair, or replace, maintenance is minimized - and worker/environmental safety is also improved through leak-free operation.



Sunflo High Pressure Pumps are also a popular choice for reflux applications: For some midstream applications which do not require API compliance, more cost-effective pumps are available that still offer similar performance. Sunflo Industrial Grade pumps are the preferred choice for applications with low NPSH requirements. Their small footprint enables them to be deployed in any plant environment. 316 stainless steel construction (with higher alloys available) enables Sunflo pumps to resist corrosion, and Sunflo's Thrust Bearing capabilities enable the pumps to withstand upset conditions and operate reliably round the clock.

MOLECULAR SIEVE DEHYDRATION:

Because Natural Gas condenses to LNG at a temperature of -260°F (-160°C), and water freezes at just 32°F (0°C), wet natural gas must be dehydrated in mole sieves to prevent ice from forming.

Mole sieve dehydration units remove water vapor from gas as it enters the midstream process after amine treating. A mole sieve utilizes molecular materials to sift and separate water from gas. The basic mole sieve design consists of two (or more) units. One unit operates in dehydration mode with the other in regeneration mode. As the dehydration unit becomes saturated with water vapor, it is automatically switched to regeneration mode while the regeneration unit becomes active in dehydration mode.

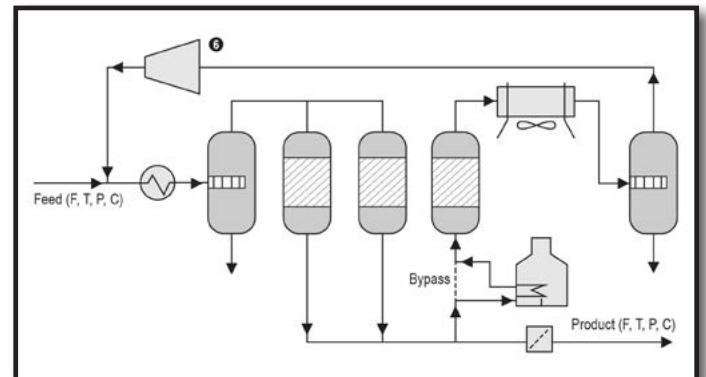

Sundyne integrally geared centrifugal compressors are precision engineered to provide pulsation and vibration free operation. Built to meet API standards, they will run continuously for up to 5 years, delivering oil-free process gas with no emissions. Their compact footprint and high efficiency make them perfect for handling mole sieve regeneration and dehydration.

CRYOGENIC PROCESSING:

A cryogenic processing plant (or a stripping plant) cools natural gas to -120°F (-84°C) in order to condense butane, ethane and propane, which naturally occur within the natural gas as NGL's or Natural Gas Liquids.

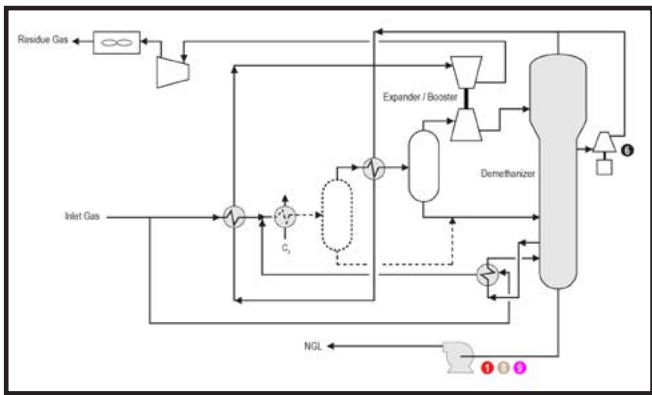

Sundyne integrally geared centrifugal compressors are widely utilized for regeneration of the demethanizer process. They can run continuously for 5 years, and their unique modular base plant is easy to install into any process environment.



Sundyne OH2, OH3 and OH5 process pumps are widely utilized for reliable, safe and efficient transportation of NGL's once they have been separated from the natural gas. Sundyne pumps are engineered to meet API 610 / ISO 13709 standards and deliver rugged reliability in a compact footprint.

HOT OILS:

Hot oil systems are designed to store and move heat transfer fluids that are required for midstream gas process heating. The heat transfer fluid is normally stored in an elevated and insulated vessel. Sundyne HMD/Kontro sealless magnetic drive centrifugal pumps are utilized to circulate the heated fluid from the storage tank through an electric process heater, gas fired heater, or exhaust heat exchanger. The heat transfer fluid's elevated temperature is then used to safely heat a process system and is then returned to the storage vessel.

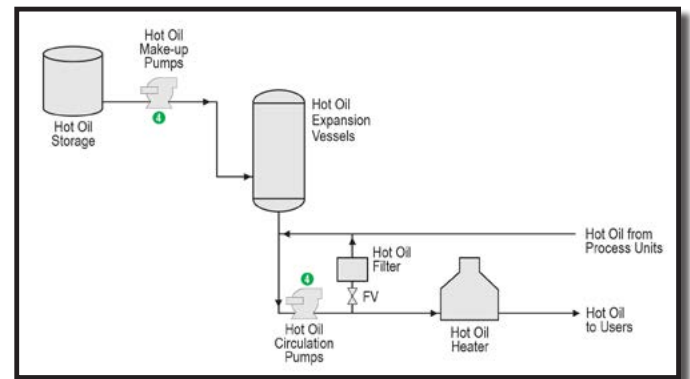

Sundyne HMD/Kontro sealless magnetic drive centrifugal pumps have a large temperature range and do not leak, making them a perfect choice for handling heat transfer fluids. Worker and environmental safety are paramount in plants processing harsh chemicals. Metallic construction enables the pumps to effectively handle harsh materials, at a wide range of temperatures. ZeroLoss containment shells increase temperature ranges from -40°C to $+150^{\circ}\text{C}$, while bolstering the pump's resistance to thermal shock.

Why Sundyne Pumps & Compressors for Midstream Applications?

The abundance of new gas discoveries in the Permian Basin and throughout Asia and the Middle East have clearly shown how gas will play a more prominent role in power generation, and also in the creation of value added refined products and industrial chemical production.

Numerous reports estimate that investment for new pipelines, processing and refining infrastructure will top \$300 billion in new spending by 2035. These new plants and processing facilities will need to leverage the industry's best technology – such as Sundyne's pumps & compressors - which have proven their reliability for decades in many of the world's largest refineries and processing facilities.



■ **Sundyne sealless pumps** are designed from the frame up to meet stringent API guidelines, thus eliminating unwanted emissions and protecting plant personnel and the environment. Built around a streamlined, modular design philosophy, Sundyne pumps allow for fast, self-contained preventative maintenance, thereby maximizing uptime and keeping the midstream chain operating seamlessly.



■ **Sundyne integrally geared centrifugal compressors** meet all API specifications and are designed to provide pulsation- and vibration-free operation for up to 5 years of continuous operation with no emissions. Sundyne compressors are ideal for skid packaging due to their unique modular baseplate, which is easy to install into any process environment.

MIDSTREAM

PUMPS & COMPRESSORS USED AROUND THE GLOBE FOR MIDSTREAM PROCESSING APPLICATIONS



OH3



OH5



API 610



API 685



OH2

Safety

Matters

The ZeroLoss non-metallic containment shell is an excellent choice for handling light hydrocarbons including amine as vapor pressure is significantly reduced and the danger of dry running pumps is significantly reduced.

Sundyne ZeroLoss Non-metallic Containment Shell for API 685 Sealless Magnetic Drive Pumps



Sundyne HMD Kontro VapourView® Ultrasonic Monitor for API 685 Sealless Magnetic Drive Pumps



This patented ultrasonic system reduces and in many cases eliminates dry running, entrainment and cavitation that often occur when handling light hydrocarbons like amine treating in midstream gas processing operations.

Sundyne equipment can withstand rigorous conditions and provide a perfect solution for midstream engineers concerned with amine treatment, molecular sieve dehydration, cryogenic processing and hot oils.

"..If that compressor goes down, the plant goes down. That's why we commissioned a Sundyne."

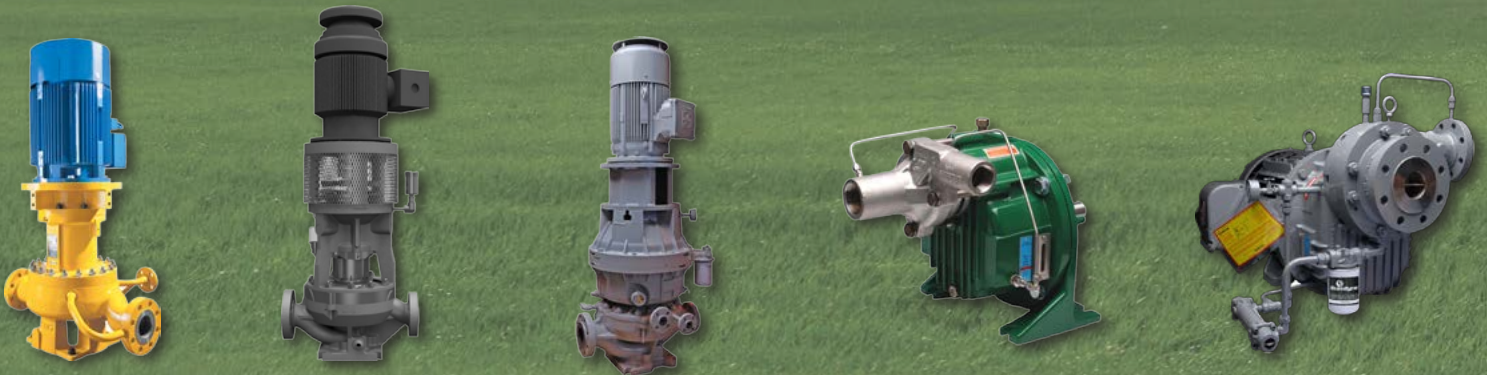

INTEGRALLY GEARED COMPRESSORS | INDUSTRIAL GRADE PUMPS



Backed By Global Support

Sundyne offers some of the fastest delivery times in the industry via the FastLane program. Sundyne also backs every product shipped with a full range of aftermarket support services. The global Sundyne service team extends the value of Sundyne's highly engineered pumps & compressors beyond the point of sale, protecting the investment, and insuring a trouble-free customer experience.

Our Aftermarket Programs Include:

- Expedite Programs
- Maintenance Kits
- Conversion Programs
- Gearbox Exchanges
- Service Schools
- On-Site Service
- Overhaul and Repair Services



Sundyne's Reliability Assurance Kits deliver trouble free maintenance at regular intervals. To learn more about this convenient new service program, visit www.sundyne.com.

COMPRESSORS

PUMPS

GENUINE PARTS

SERVICE



Sundyne, LLC
14845 West 64th Avenue
Arvada, Colorado 80007
USA
1-866-Sundyne
Phone: 1 303 425 0800
Fax: 1 303 425 0896
www.sundyne.com

Sundyne HMD/Kontro Sealless Pumps, Ltd.
Marshall Road
Hampden Park Industrial Estate
Eastbourne East Sussex, BN22 9AN
United Kingdom
Phone: +44 1323 452000
Fax: +44 1323 503369

Sundyne Marelli Bombas, S.R.L.
Ctra. Madrid-Toledo, Km.30.8
45200 Illescas
Toledo, Spain
Phone: +34 925 53 45 00
Fax: +34 925 51 16 00

Sundyne China
Building 1, No. 879 Shen Fu Road
XinZhuang Industrial Zone
Min Hang District
Shanghai, China 201108
Phone: +86 21 50555005
Fax: +86 21 54425265

Sundyne International S.A.
13-15, Bld. Eiffel - B.P. 30
21604 Longvic Cedex
France
Phone: +33 (0)3 80 38 33 00
Fax: +33 (0)3 80 38 33 66



**RELIABILITY
REALIZED.**

All information provided is subject to change without notice.

© 2018 Sundyne, LLC
All Rights Reserved. Other logos and trade names are property of their respective owners.

Midstream Brochure_041018:
US (v.3) POD