

The KM is a perfect fit for handling most corrosive or acidic applications as they relate to the chemical, specialty chemical and steel industries.

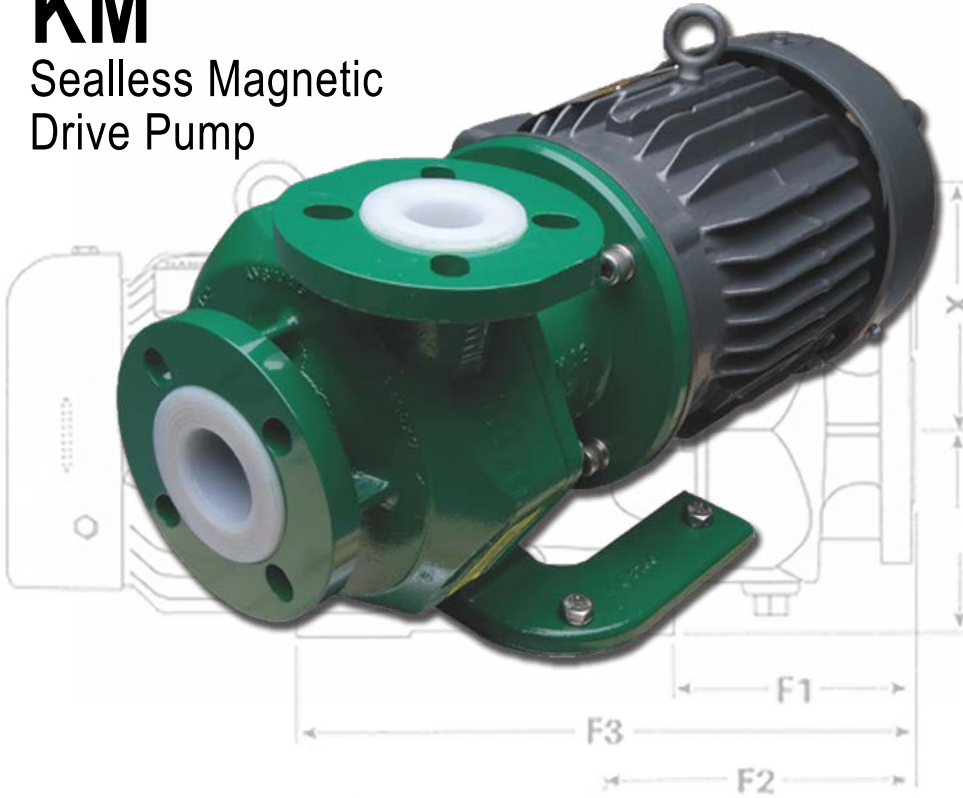

KM

Sealless Magnetic Drive Pump



General industry chemical process sealless magnetic drive non-metallic centrifugal end suction pump.

The KM delivers:

- Flows to: 146 GPM (34 m³ / hr)
- Total Dynamic Head: 140 ft (43 m)

Simple by design, Sundyne Ansimag pumps deliver world class performance in a remarkably compact footprint. With no seals or mechanical couplings to leak or fail, these pumps are the safest choice for those looking to protect personnel and the environment. Additionally, Sundyne sealless pumps feature fewer wetted parts than competitive products and a powder coat finish to prevent corrosion, delivering enhanced durability, optimal reliability and lower through-life costs over traditional sealed pumps. Built to meet exacting ASME / ANSI B73.3 chemical process pump standards, Sundyne sealless pumps are dimensionally interchangeable and represent the easy upgrade option from standard mechanically sealed pumps.

Specifications

| | | | |
|-----------------------------------|--|---------------------------|----------------------------------|
| Heads To | 10 to 140ft | 2 to 30m | 60HZ: 3 to 43m |
| Flows To | 1 to 147gpm | 8 to 27m ³ /hr | 60HZ: 10 to 34m ³ /hr |
| Max Power | 1 to 7.5hp | 1 to 5.5kW | |
| Temp Range | -20 to 250°F | -29 to 121°C | |
| Number of Stages | 1 | | |
| Max Case Working Pressure | 150 psi | 10.3 bar | |
| Standard Delivery | 2 Weeks | | |
| Bearing Materials Available | Silicon Carbide (Standard) Carbon Graphite (Optional) | | |
| Hydrotest Pressure | 225 psig | 15.5 bar | |
| Max Viscosity | 700 SSU (150 centistokes) | | |
| Solids Range | Concentration to 20% w/w Size: 1/16" (1.6mm) diameter | | |
| Motor Details | NEMA C-face and IEC B5 | | |
| Mounting Configurations | Horizontal close coupled | | |
| Number of Available Hydraulics... | 3 | | |
| Seal Configurations Available | Sealless | | |
| Available Flanges | Universal Flange fits ANSI Class 150 RF, ISO PN16, and JIS 10 kg/cm2 | | |
| Materials of Construction | Carbon Fiber Reinforced ETFE (Standard) Glass Fiber Reinforced PFA (Optional) | | |

APPLICATIONS

- Ethanol
- Solvents
- Plastics
- Specialty Chemicals
- Wastewater Treatment
- Corrosive Services
- Metal Pickling
- Water Supply
- Acid Transfer
- Flammable Liquids



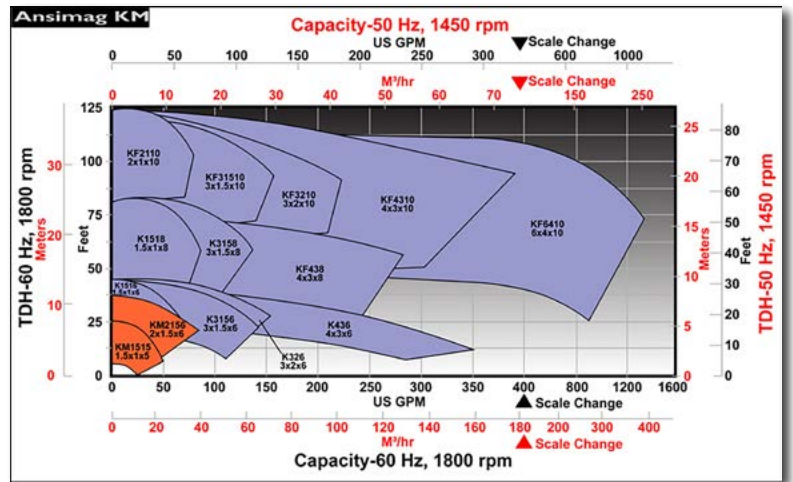
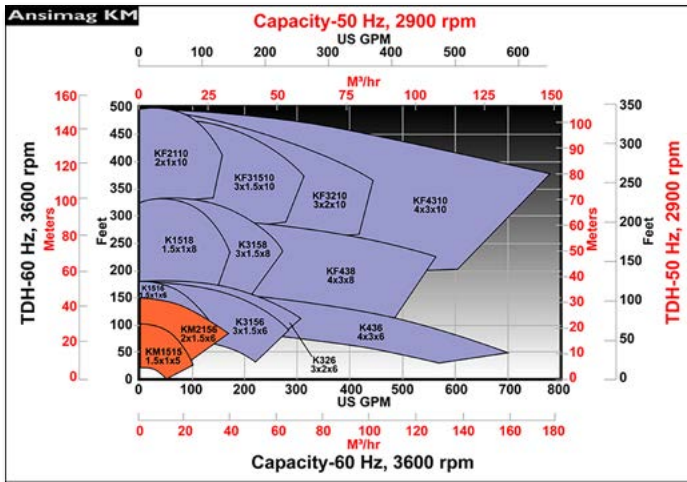
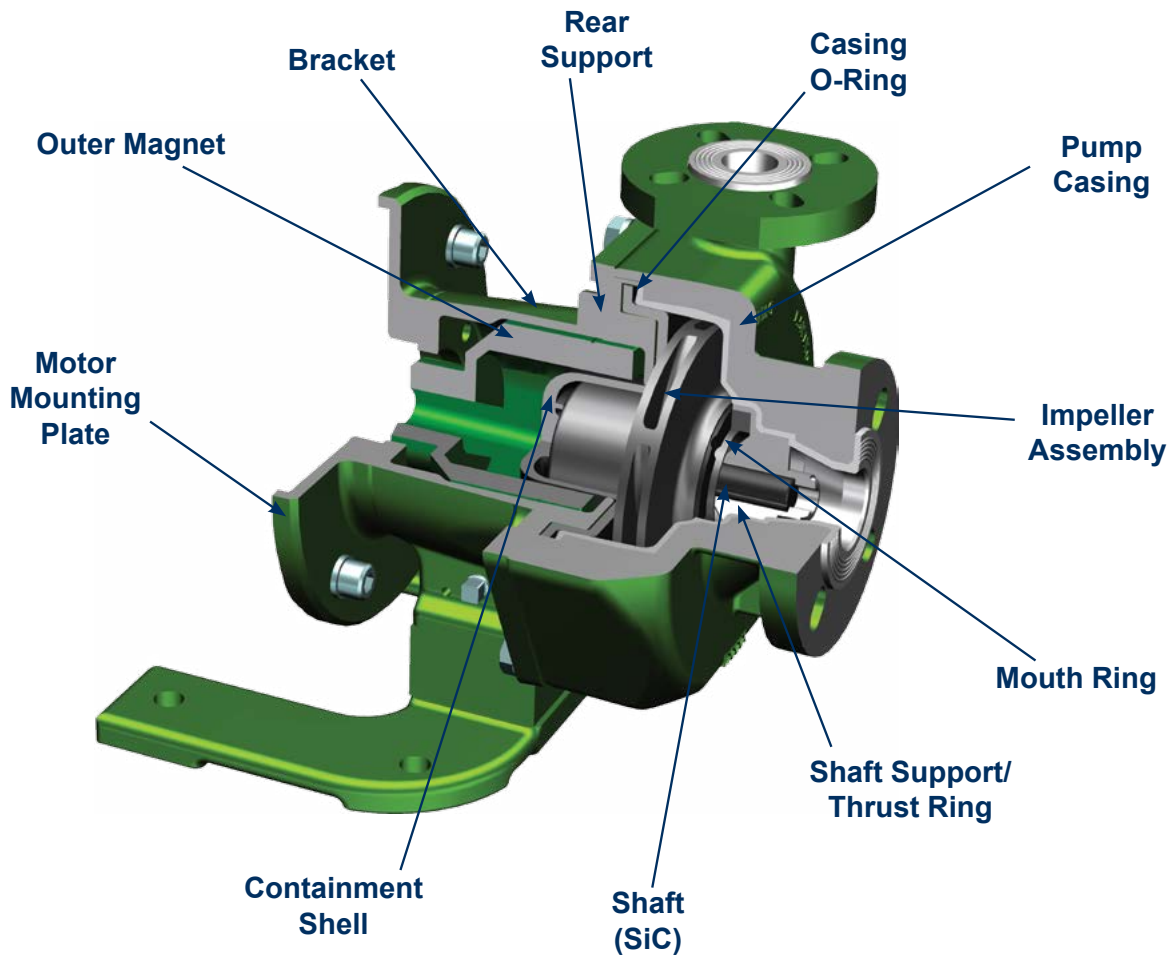

Visit our website at: www.sundyne.com